



Germany Beyeler Servo Nc MetalPlate Production Line



Robot equipment



The Traction Machine Production Line



Advanced Elevator Controller



Italy Prima Laser Cutting Equipment



Germany Beyeler Ncmulti-station Machining Center



Car Wall Automatic Production Area



Escalator And Moving Walkway Production Line



Germany Wagner Automatic Spraying Production Line



Advanced Equipment

16 production lines, top-grade manufacture craft & tech

ESNOW Elevator puts out 16 advanced production lines including fully automatic flexible metal-working production line, medium thickness metal-working production line, production line control system, robot welding production line, automatic painted production line etc. It has a complete set of modern digital machining equipment, testing facilities in order to warrant perfect product quality.

05 Product series

It provides global transport with comprehensive solution plans

The perfect vertical transport solution plan

SUZHOU ESNOW ELEVATOR EQUIPMENT CO., LTD. offers high speed elevator, small machine room elevator, machine room-less elevator, passenger elevator, observation elevator, bed elevator, fire-fighting elevator, freight elevator, automobile elevator, escalator, moving walk, 3D vertical parking system. It supplies vertical transport solution plans for public building, commercial building, residential building, industrial building and so on.

Product	Type	Load Range(kg)	Speed Range (m/s)
Passenger Elevator	JSPS20	400~2000	1.0/1.6/1.75/2.0/2.5/3.0/3.5/4.0
	JSPS30	630~1050	1.0/1.5/1.6/1.75/2.0
	JSPS50	630~1050	1.0/1.5/1.6/1.75/2.0
	JSPS70	1000~1600	4.5/5.0/5.5/6.0/6.5/7.0/8.0
	JSPN20	400~1600	1.0/1.6/1.75/2.0
Observation Elevator	JSOS	630~1600	1.0/1.75/2.0/2.5
Home Elevator	JSV20	250~400	0.22/0.28/0.3/0.4
Bed Elevator	JSBS	1000~2000	1.0/1.6/1.75/2.0/2.5
Fireman Elevator	JSPS20F	1000	3.5/4.0
Freight Elevator (Traction)	JSF	1000~5000	0.25/0.5/1.0
	JSFN	2000	0.5/1.0
Freight Elevator (Hydraulic)	JSFH10	1000~5000	0.25/0.5
Car Elevator	JSA10	3000~5000	0.25/0.5

Product	Type	Inclination	Step (pallet) Width	Rise/span
Escalator (Commercial)	JSE20	30°	600/800/1000	≤ 7.5m
		35°	600/800/1000	≤ 6m
Escalator (Public Traffic)	JSE30	30°	600/800/1000	≤ 16m
		35°	600/800/1000	≤ 30m
Moving Walk	JSM20	10°/11°/12°	800/1000	≤ 8m
	JSM15	0°-6°	800/1000	≤ 150m



Small machine room passenger elevator

Small machine room passenger elevator strictly accords with German manufacture technology, advanced industrial technology. It optimizes space design with intellectual & compact mechanical parts. It effectively reduces top space, saves construction cost. It features as energy-saving, environment-protection, safe, stable, comfortable travel. It also has other advantages. It provides all kinds of modern buildings with reliable solution plans.



Machine room-less passenger elevator

It perfectly shows energy-saving, consumption-reducing, environment-protection concept. We try hard to save building area, enhance design freedom. It gives a full play of green human-centered ideas. Compared with same load horizontal gear elevator, it can save more power and building area. Machine room-less passenger elevator breaks through a "must" of machine room. It provides limited space with innovative possibilities.

07 Product series



Observation elevator

Fine and exquisite outline model, delicate inner car decoration and distinctive styles of human-centered interface design invisibly show your outstanding social status and remarkable grade.

Car wall applies highly secure laminated glass material. Inner lamination layer nicely resists radiation.

It prevents from energy loss, effectively isolates sound.

It applies large area car wall glass. It produces absolutely fine sight-seeing vision.

Smooth outline design lines add flowing aesthetics for the building during transport process.



Home elevator

On the basis of your original household environment, ESNOW home elevator applies "de-composition and re-composition" methods. It chooses superior materials to save power and energy. It uses individual, graceful, noble design styles to car decoration. Therefore ESNOW home elevator perfectly combines with the building. It becomes a beautiful and advanced "electrical home appliance" in your house.



hospital elevator

Based on foundation of special requirements, ESNOW hospital elevator series fully consider peculiarity in medical treatment institutes. It fulfills convenient travel for vast patients. Precise speed control makes patients and medical staffs feel very stable and comfortable. It displays human-centered caring.



09 / Passenger elevator decoration



ESNO01



ESNO02

ESNO01 (Standard)

Ceiling: Hairline stainless steel, acrylic lighting decoration, down lamp
Car wall: Hairline stainless steel
Handrail: None
Floor: PVC

ESNO02 (Optional)

Ceiling: Hairline stainless steel, acrylic transparent board, down lamp
Car wall: Hairline stainless steel, mirror stainless steel
Handrail: Stainless steel single round handrail
Floor: PVC



ESNO05



ESNO06

ESNO05 (Optional)

Ceiling: Mirror stainless steel frame, acrylic lighting decoration
Car wall: Hairline stainless steel, mirror etched stainless steel
Handrail: Stainless steel single round handrail
Floor: PVC

ESNO06 (Optional)

Ceiling: Mirror stainless steel frame, acrylic lighting decoration
Car wall: Hairline stainless steel, mirror etched stainless steel
Handrail: Stainless steel single round handrail
Floor: PVC



ESNO03



ESNO04

ESNO03 (Optional)

Ceiling: Mirror stainless steel frame, acrylic transparent board, down lamp
Car wall: Hairline stainless steel, mirror etched stainless steel
Handrail: Stainless steel single round handrail
Floor: PVC

ESNO04 (Optional)

Ceiling: Hairline stainless steel frame, acrylic lighting decoration, down lamp
Car wall: Hairline stainless steel, mirror etched stainless steel
Handrail: Stainless steel single round handrail
Floor: PVC



ESNO07



ESNO08

ESNO07 (Optional)

Ceiling: Mirror stainless steel frame, acrylic lighting decoration, down lamp
Car wall: Hairline stainless steel, mirror etched stainless steel
Handrail: Stainless steel flat handrail
Floor: PVC

ESNO08 (Optional)

Ceiling: Mirror stainless steel frame, acrylic transmitting top plate
Car wall: Stainless steel hairline on both sides, combination of stainless steel hairline and etched mirror at rear wall
Handrail: None
Floor: PVC

11 / Passenger elevator decoration



ESNO09



ESNO10

ESNO09 (Optional)

Ceiling: Mirror stainless steel frame, acrylic lighting decoration
Car wall: Hairline stainless steel, mirror etched stainless steel
Handrail: Stainless steel flat handrail
Floor: PVC

ESNO10 (Optional)

Ceiling: Mirror stainless steel frame, acrylic lighting decoration
Car wall: Hairline stainless steel, mirror etched stainless steel
Handrail: Stainless steel single round handrail
Floor: PVC



ESNO13



ESNO14

ESNO13 (Optional)

Ceiling: Titanium gold mirror stainless steel, acrylic transparent board
Car wall: Titanium gold stainless steel, titanium gold mirror etched stainless steel
Handrail: Titanium gold stainless steel round handrail
Floor: PVC

ESNO14 (Optional)

Ceiling: Mirror stainless steel frame, acrylic lighting decoration, down lamp
Car wall: Titanium gold mirror etched stainless steel, hairline stainless steel
Handrail: Single crystal round handrail
Floor: PVC



ESNO11



ESNO12

ESNO11 (Optional)

Ceiling: Mirror stainless steel framework, acrylic top plate, intermediate down lamp decoration
Car wall: Stainless steel hairline on both sides, combination of stainless steel hairline and etched mirror at rear wall
Handrail: None
Floor: PVC

ESNO12 (Optional)

Ceiling: Vortical square image main body board and tube lamp combining for soft illumination design
Car wall: Stainless steel hairline on both sides, combination of stainless steel hairline and etched mirror at rear wall
Handrail: None
Floor: PVC



ESNO15

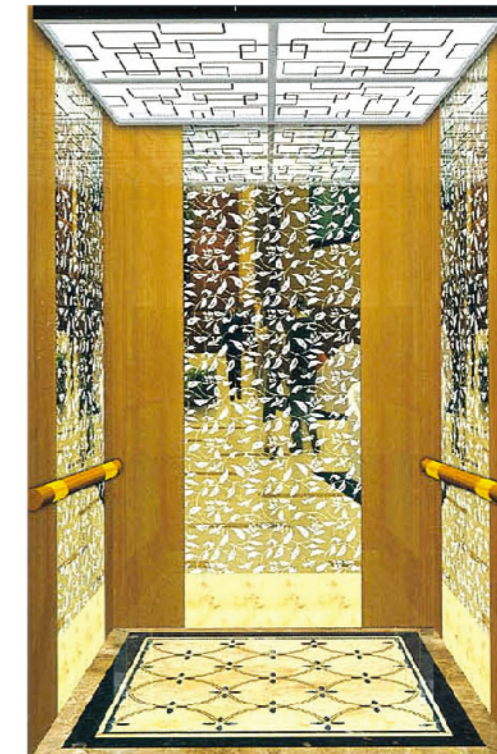

ESNO16

ESNO15 (Optional)

Ceiling: Hairline stainless steel frame, acrylic lighting decoration, down lamp
Car wall: Hairline titanium gold etching stainless steel, Hairline titanium gold etched stainless steel
Handrail: Stainless steel flat handrail
Floor: PVC

ESNO16 (Optional)

Ceiling: Hairline stainless steel frame, acrylic transparent board
Car wall: Titanium gold stainless steel, mirror etched stainless steel
Handrail: Titanium stainless steel round tube handrail
Floor: PVC

13 / Passenger elevator decoration



ESNO17



ESNO18

ESNO17 (Optional)

Ceiling : Wide arch white translucent panels soft lighting design
 Car wall : Titanium, mirror, etching, hairline, vibration
 Handrail: Round and titanium combination armrest
 Car bottom: PVC floor (optional marble)

ESNO18 (Optional)

Ceiling: Mirror stainless steel frame, acrylic
 Car wall: Mirror stainless steel, glaze glass
 Handrail: Stainless steel round tube
 Car bottom: PVC

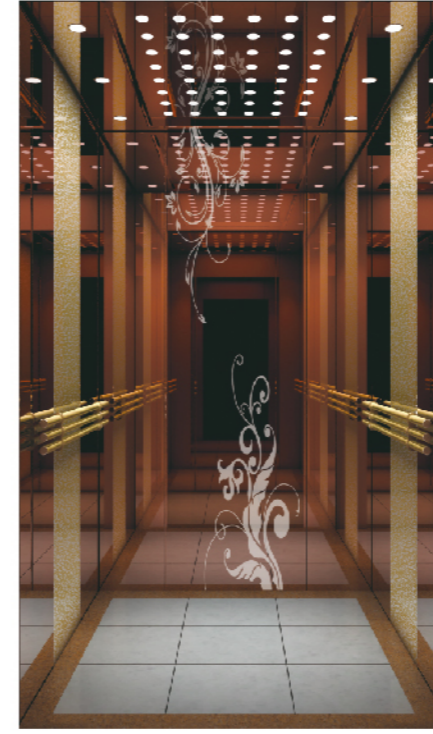

ESNO21



ESNO22

ESNO21 (Optional)

Ceiling : Rose gold mirror stainless steel framework, acrylic lighting decoration, down lamp
 Car wall : Rose gold mirror stainless steel, titanium etched stainless steel
 Handrail: Triple titanium stainless steel tubes
 Car bottom : PVC

ESNO22 (Optional)

Ceiling : Rose gold mirror stainless steel frame, acrylic lighting decoration, down lamp
 Car wall : Rose gold stainless steel, rose gold mirror etched stainless steel
 Handrail: Stainless steel single tube handrail
 Car bottom : PVC



ESNO19



ESNO20

ESNO19 (Optional)

Ceiling : Etched titanium gold mirror, central ceiling lamp, LED at four sides
 Car wall : Marble or imitation marble grain, etched stainless steel mirror plated with titanium
 Car bottom: PVC

ESNO20 (Optional)

Ceiling: Painted stainless steel frame, central gold foil paper, model design
 Car Wall: Champagne gold mirror, etched grain
 Handrail: Round transparent organic column handrail
 Car bottom: 2mm thickness PVC parquet floor



ESNO23



ESNO24

ESNO23 (Optional)

Ceiling: Titanium gold stainless steel mirror, acrylic light-emitting panel
 Car wall: Titanium gold stainless steel, Etched stainless steel mirror
 Handrail: None
 Car bottom: PVC

ESNO24 (Optional)

Ceiling: Black titanium hairline stainless steel, acrylic
 Car wall: Black titanium hairline stainless steel, mirror stainless steel, paint steel
 Handrail: Stainless steel handrails
 Car bottom: Marble

15 Observation elevator car decoration



ESN025



ESN026

ESN025 (Optional)

Car cover: Steel plate baked enamel, internal light-emitting strip closure, creamy white acrylic decoration hood
Observation wall: Round 6+6 laminated safety glass (3PCS)
Decoration ceiling: Steel plate baked enamel frame, half-transparent round lampshade, strip lighting decoration
Car wall: Hairline stainless steel
Handrail: φ38 stainless steel tube handrail
Floor: PVC

ESN026 (Optional)

Car cover: Painted steel plate and decoration lamp
Observation wall: Safety laminated glass
Decoration ceiling: Center round acrylic top panel, two-side down lamps
Car wall: Hairline stainless steel panel
Handrail: Stainless steel mono-tube handrail
Floor: PVC



ESN029



ESN030

ESN029 (Optional)

Car cover: Baked enamel steel plate, acrylic lighting decoration
Observation wall: Laminated safety glass
Decoration ceiling: Baked enamel steel plate, acrylic lamp
Car Panel: Hairline stainless steel
Handrail: Stainless steel tube handrail
Floor: PVC

ESN030 (Optional)

Car cover: Steel plate baked enamel pressed reinforced bar, acrylic lighting decoration
Observation wall: Round 6+6 laminated safety glass (3PCS)
Decoration ceiling: Baked enamel steel, cylindrical acrylic crystal lamp
Car wall: Hairline stainless steel
Handrail: Stainless steel double tube handrail
Floor: PVC



ESN027



ESN028

ESN027 (Optional)

Car cover: Painted steel plate, acrylic lighting decoration
Observation wall: 3PCS of safety laminated glass
Decoration ceiling: Mirror stainless steel
Car wall: Hairline stainless steel
Handrail: Stainless steel round handrail
Floor: PVC

ESN028 (Optional)

Car cover: Baked enamel steel
Observation wall: Laminated glass
Decoration ceiling: Mirror stainless steel, acrylic, down lamp
Car wall: Mirror stainless steel
Handrail: Stainless steel tube handrail
Floor: PVC



ESN031



ESN032

ESN031 (Optional)

Car cover: Cylindrical slant-cut titanium plate inlaid with light-emitting lampshade
Observation wall: Transparent arc glass
Decoration ceiling: Stainless steel mirror, organic lens top cover, acrylic lighting decoration
Car wall: Hairline stainless steel
Handrail: Titanium stainless steel handrail
Floor: PVC

ESN032 (Optional)

Car cover: Baked enamel steel, hairline stainless steel, lighting decoration
Observation wall: 6+6 laminated safety glass (3PCS)
Decoration ceiling: Hairline stainless steel, acrylic lighting decoration, down lamp
Car wall: Hairline stainless steel
Handrail: Stainless steel tube handrail
Floor: PVC

17 Observation elevator car decoration



ESN033



ESN034

ESN033 (Optional)

Car cover: Paint steel, hairline stainless steel
Observation wall: Toughened laminated glass
Decoration ceiling: Painted steel plate, acrylic, LED lighting
Car wall: Hairline stainless steel
Handrail: Stainless steel handrail
Floor: PVC

ESN034 (Optional)

Car cover: Paint steel, hairline stainless steel
Observation wall: Toughened laminated glass
Decoration ceiling: Painted steel plate, acrylic, LED lighting
Car wall: Hairline stainless steel panel
Handrail: Stainless steel handrail
Floor: PVC



ESN037



ESN038

ESN037 (Optional)

Car cover: Round corner-cut steel plate baked enamel, acrylic light-emitting
Observation wall: Safety laminated glass
Decoration ceiling: Steel plate baked enamel frame, acrylic light-emitting and down lamp
Car Wall: Hairline stainless steel
Handrail: Stainless steel mono-tube
Floor: PVC

ESN038 (Optional)

Car cover: Steel plate baked enamel, acrylic lighting decoration
Observation wall: Safety laminated glass
Decoration ceiling: Mirror stainless steel, acrylic lighting decoration
Car wall: Laminated glass
Handrail: Ø38 stainless steel tube
Floor: PVC



ESN035



ESN036

ESN035 (Optional)

Car cover: Baked enamel steel plate, acrylic lighting decoration
Observation wall: Toughened laminated glass
Decoration ceiling: Titanium gold mirror stainless steel, acrylic lighting decoration, LED lighting
Car wall: Titanium gold mirror stainless steel
Handrail: Stainless steel handrail
Floor: PVC

ESN036 (Optional)

Car cover: Baked enamel steel plate, acrylic decoration lamp pole
Observation wall: Toughened laminated glass
Decoration ceiling: Painted steel plate, acrylic, LED lighting
Car wall: Hairline stainless steel
Handrail: Stainless steel handrail
Floor: PVC



ESN039



ESN040

ESN039 (Optional)

Car cover: Titanium gold etching, steel plate baked enamel
Observation wall: Safety laminated glass
Decoration ceiling: Steel plate baked enamel, acrylic lighting decoration
Car wall: Titanium gold mirror etched stainless steel
Handrail: Titanium gold double-tube handrail
Floor: PVC

ESN040 (Optional)

Car cover: Baked enamel steel plate, acrylic lighting decoration
Observation wall: Toughened laminated glass
Decoration ceiling: Painted steel plate, acrylic, LED lighting
Car wall: Hairline stainless steel
Handrail: Stainless steel handrail
Floor: PVC

19 Home elevator car decoration



ESN-J201

Ceiling: Transparent glass, down light
Car wall: Mirror stainless steel, hairline stainless steel
Handrail: Stainless steel flat tube
Floor: PVC



ESN-J202

Ceiling: Mirror stainless steel frame, acrylic
Car wall: Full sightseeing type, glass
Floor: PVC floor(optional marble)



ESN-J203

Ceiling: Wood grain lamination, acrylic light-emitting panel
Car wall: Wood-grain veneer, glass mirror
Floor: PVC



ESN-J204

Ceiling: Titanium gold mirror, titanium gold mirror etching,
Car wall: Titanium gold mirror etching, marble, titanium gold mirror
Floor: PVC



ESN-J205

Ceiling: Sight glass, acrylic, parchment lamp
Car wall: Mirror etched titanium plating, annatto peritoneal steel plate, walnut lines
Floor: PVC



ESN-J206

Ceiling: Mirror stainless steel, White organic glass light-emitting panel, LED down lamp
Car wall: Wood grain decoration panel
Floor: Parquet floor tile



21 / Home elevator car decoration



ESN-J207

Ceiling: Mirror stainless steel , acrylic light cover
 Car wall: Titanium gold, etched stainless steel, mirror stainless steel
 Floor: PVC



ESN-J208

Ceiling: Rose gold stainless steel acrylic spot-light
 Car wall: Rose gold etched stainless steel, white stainless steel mirror, glass mirror
 Handrail: Rose gold stainless steel
 Floor: Marble parquet



ESN-J209

Ceiling: Mirror stainless steel, hairline stainless steel, shoot the light
 Car wall: Hairline stainless steel, laminated safety glass
 Handrail: Stainless steel tube
 Floor: PVC



ESN-J210

Ceiling: Wood grain lamination, acrylic light-emitting panel
 Car wall: Wood-grain veneer
 Floor: PVC

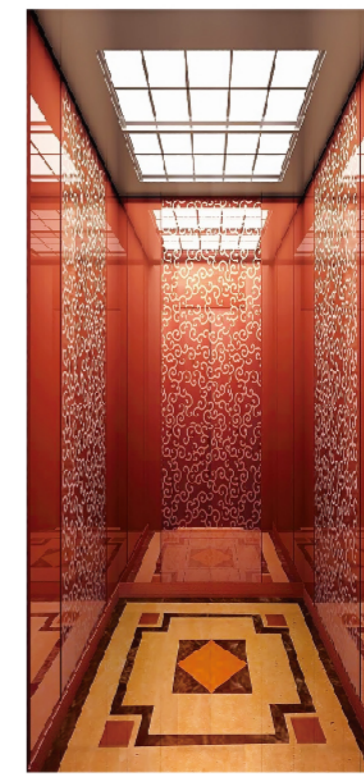

ESN-J211

Ceiling: Hairline stainless steel, acrylic transparent board
 Car wall: Rose gold mirror stainless steel, rose gold mirror etched stainless steel
 Floor: PVC



ESN-J212

Ceiling: Wood baking finish frame, mirror stainless steel
 Car wall: baking finish, glass mirror, wall paper decoration
 Floor: Quartz stone



23 Human-machine interface

ESN-C01 (Standard)

Panel material: Hairline stainless steel
Display screen: Single-color LCD

Button: Round micro-stroke button
Parking number: 2 - 48 parking floors



ESN-C01

• Display screen



• Button



Round button
Standard

• Panel material

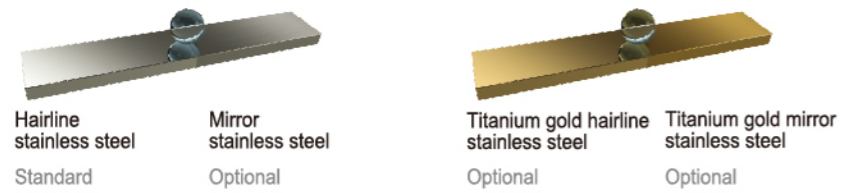

• Hall call box



ESN-C01-1
Simplex

ESN-C01-2
Duplex

ESN-C02 (Optional)

Panel material: Hairline stainless steel
Display screen: Dot matrix display

Button: Round micro-stroke button
Parking number: 2 - 48 parking floors



ESN-C02

• Display screen



• Button

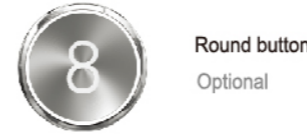

Round button
Optional

• Hall transom indicator



JS005-1-3

• Panel material

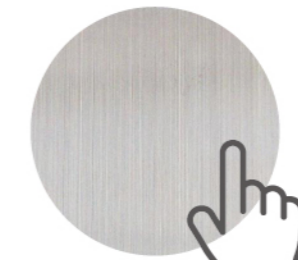

Fingerprint resistant stainless steel

• Hall call box



ESN-C02-1
Simplex

ESN-C02-2
Duplex

25 Human-machine interface

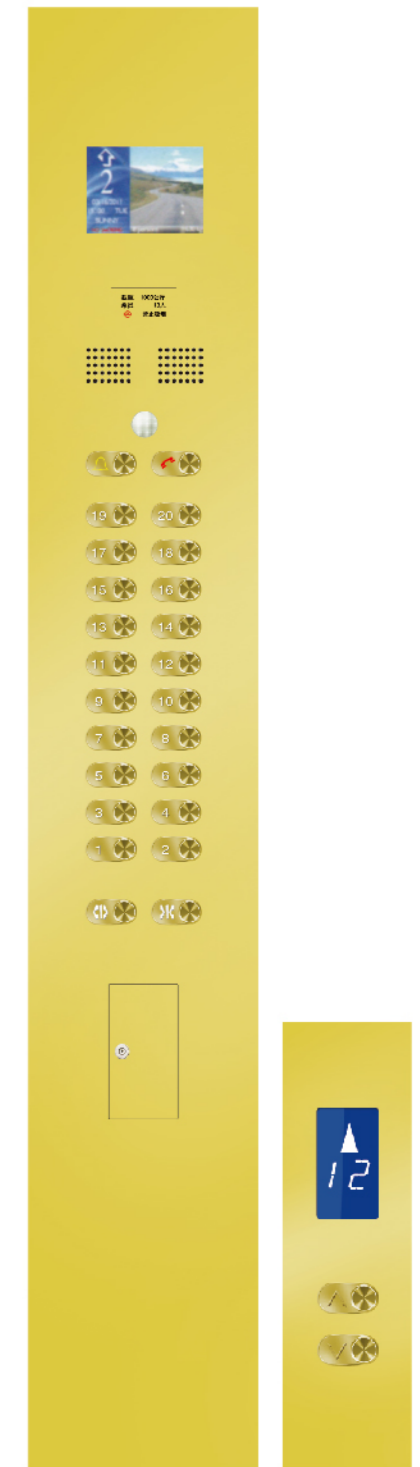
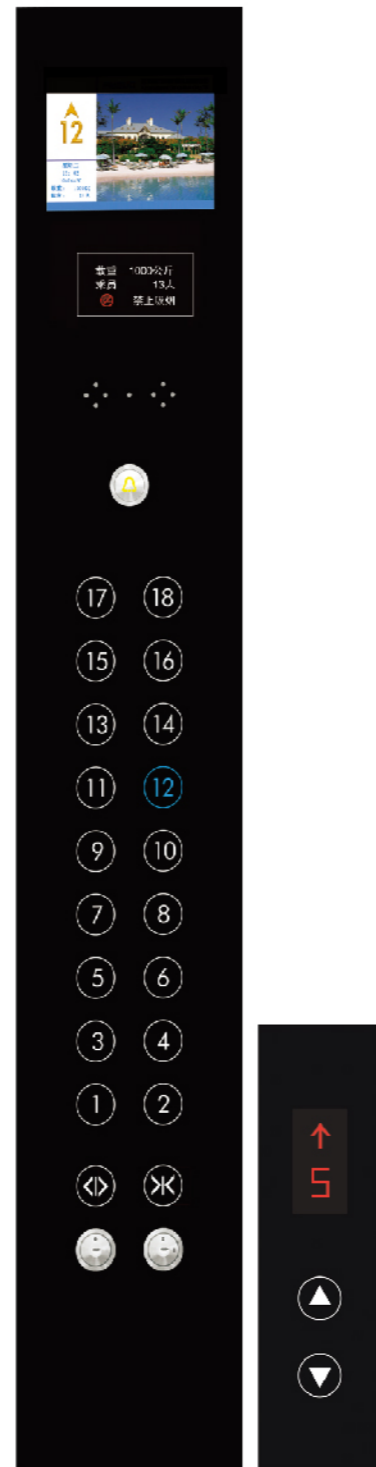

27 Human-machine interface



ESN-C07
(Optional)

ESN-C08
(Optional)

ESN-C09 (Optional)

Panel material: Titanium stainless steel
Display screen: Single-color LCD

Button: Round micro-stroke button
Parking number: 2 - 48 parking floors

• Display screen

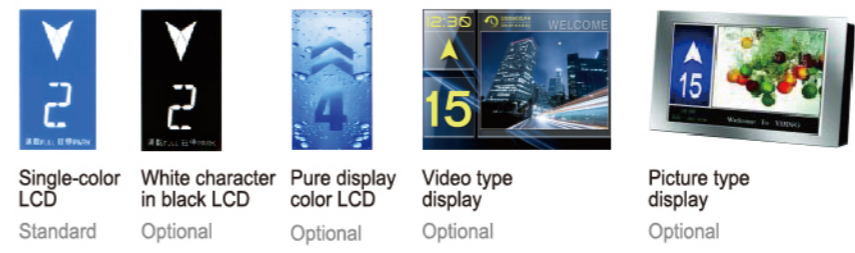

• Button



Round button
Optional

• Panel material



Hairline stainless steel
Standard

Mirror stainless steel
Optional

Titanium gold hairline stainless steel
Optional

Titanium gold mirror stainless steel
Optional

• Hall call box



ESN-C09-1
Simplex

ESN-C02-2
Duplex



ESN-C09
Integrated operation panel

29 Human-machine interface



One-piece operating box

ESN-C10
(Optional)

Panel / Rose Gold hairline stainless steel panel
Button / Rectangular button
Display / Multimedia display



Operation panel for disabled



ESN-C11
Standard



ESN-C12
Optional

Hall transom indicator



ESN-HX01



ESN-HX02



ESN-HX03



ESN-HX04

31 / Ceiling decoration



ESN-D201



ESN-D202



ESN-D203



ESN-D204



ESN-D205



ESN-D206



ESN-D207



ESN-D208



ESN-D209



ESN-D210



ESN-D211

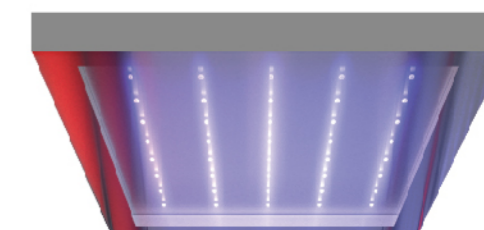

ESN-D212



ESN-D213



ESN-D214

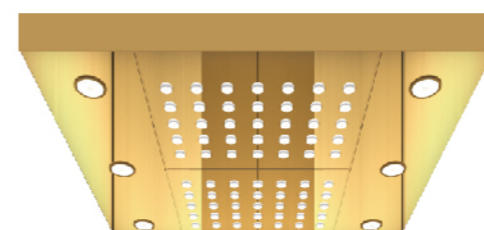

ESN-D215



ESN-D216



ESN-D217

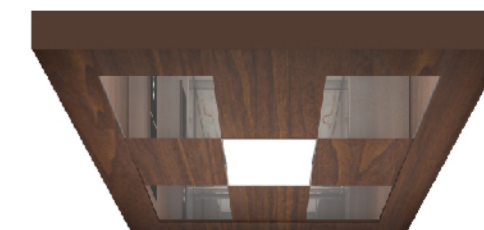

ESN-D218



ESN-D219



ESN-D220



ESN-D221

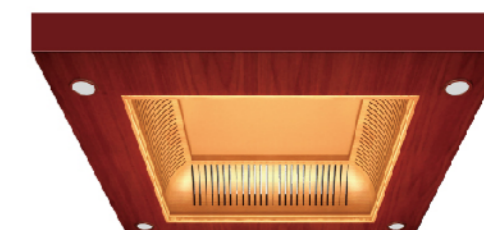

ESN-D222

33 / Landing door



ESN-M002

Landing door: Mirror etched stainless steel
Narrow jamb: Hairline stainless steel



ESN-M003

Landing door: Rose gold mirror etched stainless steel
Narrow jamb: Rose gold mirror stainless steel



ESN-M004

Landing door: Titanium gold etched stainless steel hairline
Narrow jamb: Titanium gold mirror stainless steel



ESN-M005

Landing door: Titanium gold etched stainless steel mirror
Narrow jamb: Titanium gold mirror stainless steel



ESN-M201



ESN-M202



ESN-M203



ESN-M204



ESN-M205



ESN-M206



ESN-M207

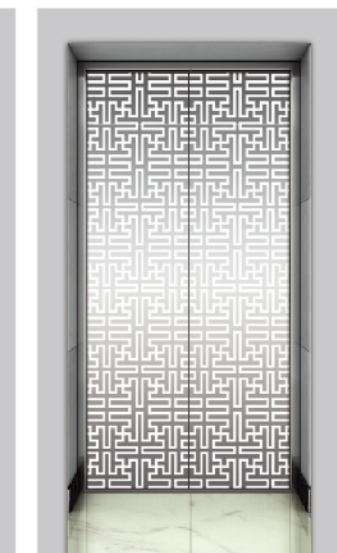

ESN-M208



ESN-M209



ESN-M210



ESN-M211



ESN-M212

35 / Handrail series

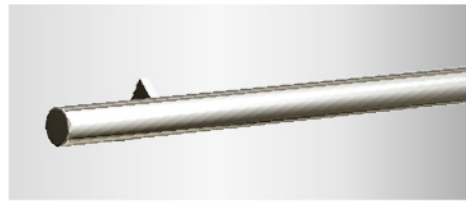

ESN-FS001

Hairline stainless steel (optional stainless steel mirror, titanium gold stainless steel, rose gold)

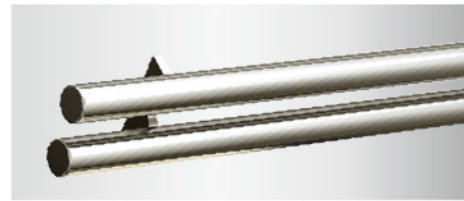

ESN-FS002

Hairline stainless steel (optional stainless steel mirror, titanium gold stainless steel, rose gold)



ESN-FS003

Hairline stainless steel



ESN-FS004

Combination of round wood and titanium gold

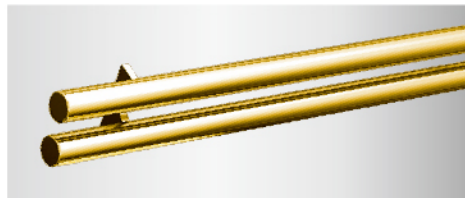

ESN-FS201

Stainless steel pipe titanium double combination



ESN-FS202

Stainless steel pipe titanium triple combination



ESN-FS203

Logs, titanium gold



ESN-FS204

Organic board arm

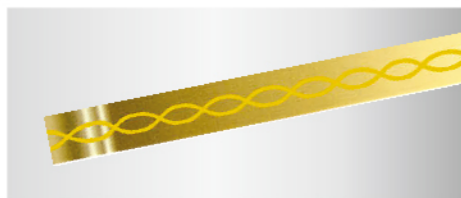

ESN-FS205

6mm stainless steel titanium short lines, etching, arc head

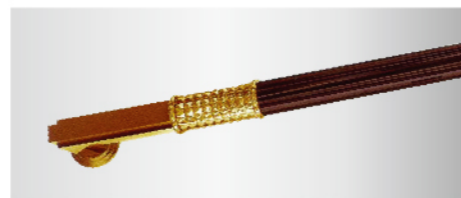

ESN-FS206

Titanium European pattern handrails, log combination

36 / Floor series

PVC floor series

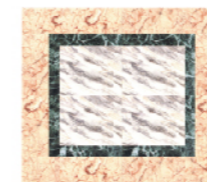

ESN-DB001

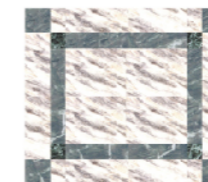

ESN-DB002

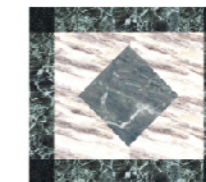

ESN-DB003

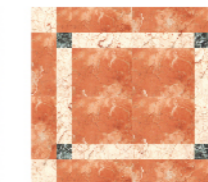

ESN-DB004



ESN-DB005

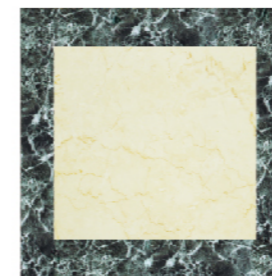

ESN-DB201

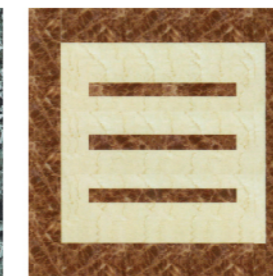

ESN-DB202



ESN-DB203



ESN-DB204



ESN-DB205

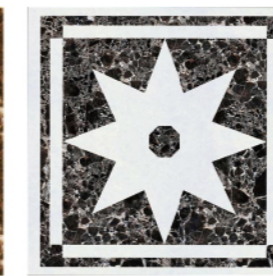

ESN-DB206

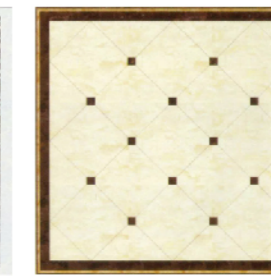

ESN-DB207

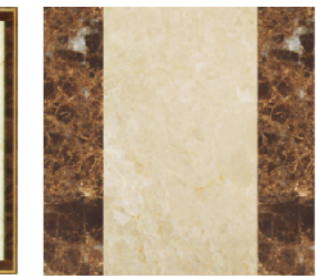

ESN-DB208

Parquet floor tile series



ESN-DB209



ESN-DB210



ESN-DB211

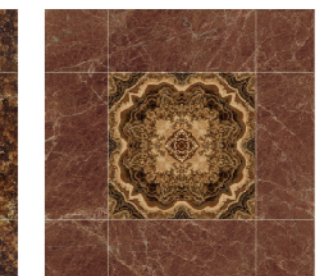

ESN-DB212

37 Escalator & moving walk

Advanced scientific research technology founds supreme quality

ESNOW escalator applies the advanced international technology and design concept for manufacture. It features as smooth travel, low noise, durable, convenient repair and so forth. It has fine and delicate structure, advanced stairway, graceful belt, deluxe and attractive outline. It provides the passengers with a completely new, bright, beautiful and comfortable feel. It grants you to appreciate the extraordinary charm and luxurious manner of modern building.

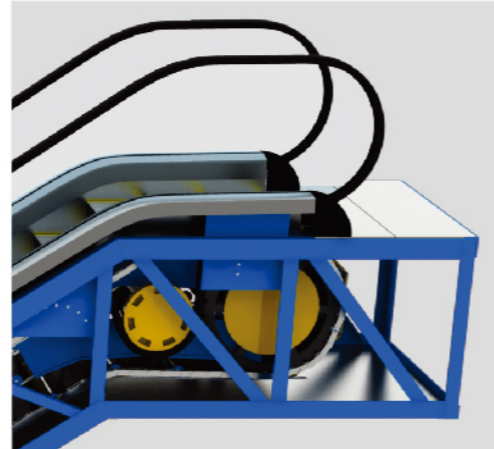

Optimized design saves the space

Minimum span size greatly saves the occupied space.

The compact pit depth design brings about a freer construction layout.

Popular outline brings about the better travel experience

ESNOW moving walk is widely applicable for large-size supermarket, public building, airport, exhibition center, transport hub etc. in the colorful modern cities. Because of its own characteristics, it can solve the transport problem of large passenger flow. It also meets the requirements of long-distance walk, transport of luggage cart; baby's cart; shopping cart; vehicle for disabled etc. People feel as easily as walking on firm earth in up / down shopping and travel. It is greatly convenient for people's outing and shopping. It becomes the first-choice solution plan in various large-size supermarkets, airports, exhibition centers, transport hubs because of its prompt, pleasant, convenient travel requirements.



39 Outstanding technology

Its superior performance design, firm and integrated spares and parts can more flexibly conform with the bilateral needs from both commercial and public traffic & transportation.

Handrail entry safety protection

Protection against risk of foreign matters being jammed into handrail entry.



Demarcation lamp

Soft and green fluorescent light sends out from the engaging teeth in-between two adjacent steps (treads) in up / down end. It reminds the passengers to pay attention to the step entry / exit horizontal section. It thus enhances the travel safely.

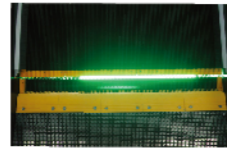

Skirt panel brush

Brush is installed between step and skirting so that the passengers' shoes do not touch the skirt panel.

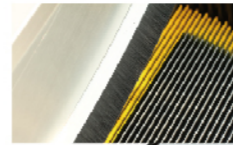

Cover-plate anti-reversal technology

It applies "movable cover-plate hook-up device". A strengthened hook-up device is installed respectively left and right of movable cover-plate. It ensures that frontline cover-plate is safe and firm under various conditions. It will not be reversed.

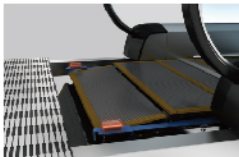

Automatic Lubricaor

It is controlled by micro-computer. It gives lubricating signal within the set period. It automatically connects with hydraulic pump for oiling and lubrication.

Comb Teeth Safety Devices

Front ends of comb teeth plates are installed on springs. If any foreign substance is nipped between moving escalator steps and static comb teeth plates; such plates will move in vertical or backward directions, and trigger the safety switches monitoring at both sides of the plates, and the escalators will be automatically stopped.

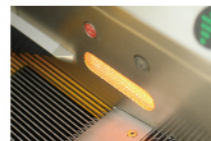

40 Standard configuration

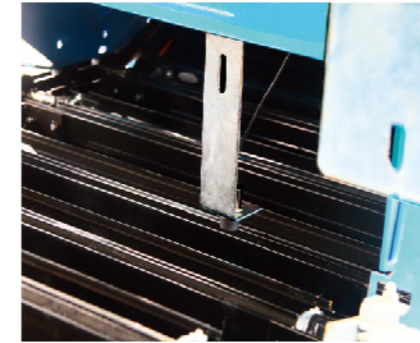

Protection device for stair deficiency

Sensor is installed in rotation of stairs of escalator; then there is deficiency of stairs, the escalator will stop operation



Handrail inlet

The escalator is designed with novel, elegant style, which displays the nobleness and imposing manner of the conveying constructions.

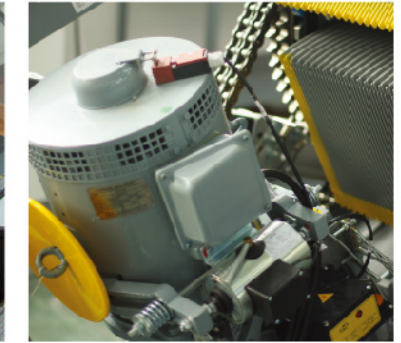
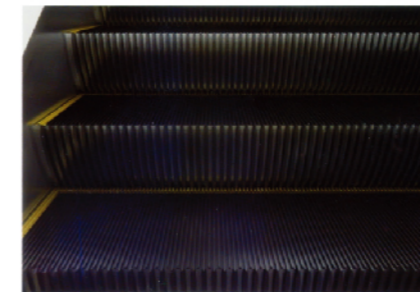

Table type traction machine

The smooth engagement and the frictional reduction guarantees the extremely low noise. It can reduce more than 60% of the noise. Compared with the traditional worm wheel drive, it is of higher driving efficiency.

Step

Black stainless steel
(Standard for indoor escalator)



Silver grey aluminum alloy
(Standard for outdoor escalator)

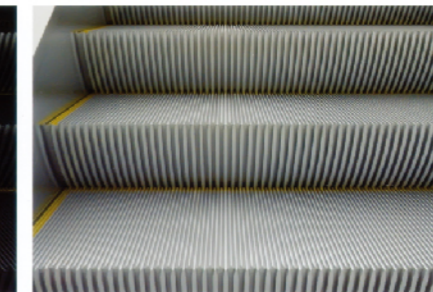

Handrail color

Black



Balustrade panel

Safety glass colorless
(Vertical handrail standard)

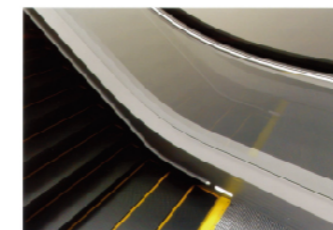

Stainless steel
(Oblique inclined handrail standard)

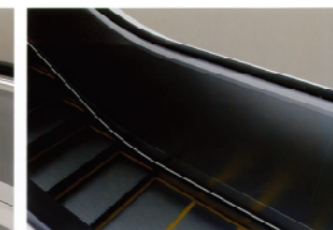

Comb teeth

Yellow resin

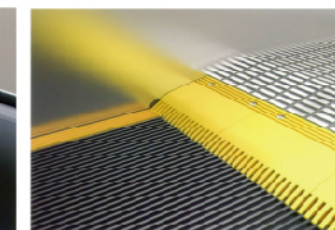

Leading edge board, floor plate

Stainless steel

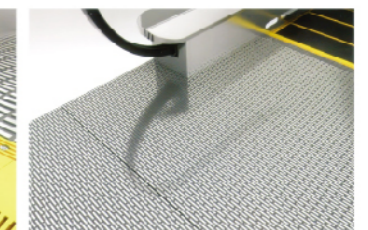

41 / Standard function

Function name	Function description
Static electricity protection	Eliminate static electricity raised from running of steps.
Emergency stop button	Push the emergency stop button to stop the escalator/moving walk against emergency raise.
Skirting protection	Protection against risk of foreign bodies being jammed into clearance between steps and skirting.
Handrail entry safety protection	Protection against risk of foreign bodies being jammed into handrail entry.
Main drive chains safety protection	Protection against risk of drive chains being breakage or undue elongation.
Over-speed protection	Protection against risk of speed being over 20% of rated speed.
Under-speed protection	Protection against risk of speed less than 80% of rated speed.
Un-intentional reversal protection	Protection against risk of unintentional reversal protection.
Lack of phase, error phase protection	Protection against risk of phase failure.
Short circuit protection	Protection against risk of short circuit.
Over-load protection	Protection against risk of motor continually over-load.
Step sagging protection	Protection against risk of steps being breakage and sagging.
Broken step chain protection	Protection against risk of step chains being breakage or under elongation.
Comb teeth safety protection	Protection against risk of foreign bodies being trapped at the point where the step enter the comb.
Handrail speed and broken handrail monitor	It detects the handrail speed and monitors the broken handrail.
Skirting anti-clamp device	It sets protection brush in the skirting on both sides of the step.
Step missing detection	It detects the step missing in the stairway.
The brake opens the monitor switch	It monitors whether the brake opens or not in during the escalator running.
Handwheel and handwheel protection cover open safety	During the use of handwheel, when open the handwheel and the handwheel protection cover, the safety switch will cut the safety circuit against escalator running.
Floor-plate monitor switch	When the pit cover plate opens, it cuts off safety circuit and stops the escalator safety switch.
Monitor of brake distance	It monitors brake distance of the escalator and auto-walk.

42 / Optional configuration

Skirting panel lighting

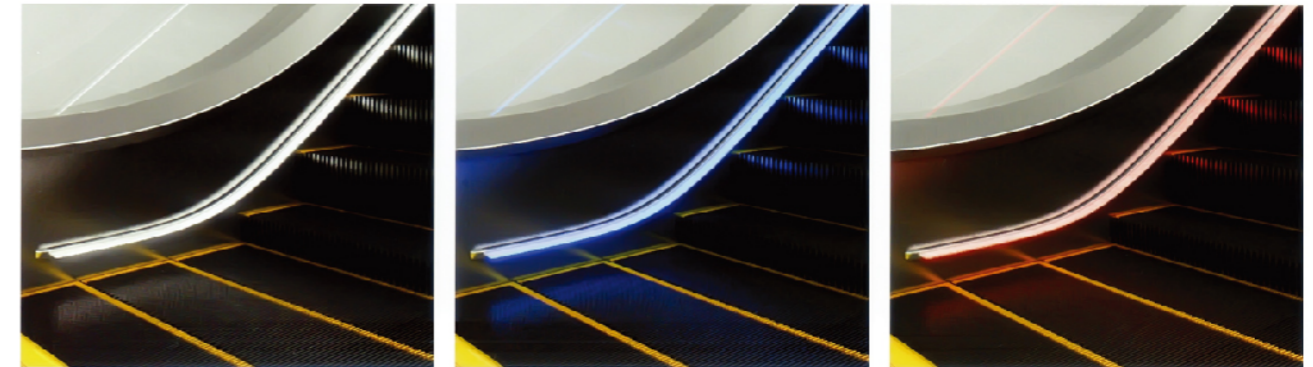

White

Blue

Red

Handrail color

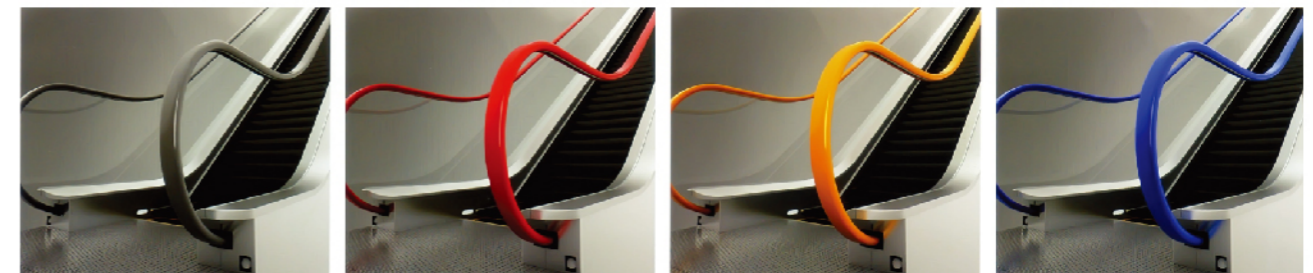

Gray

Red

Orange

Blue

Comb teeth lighting

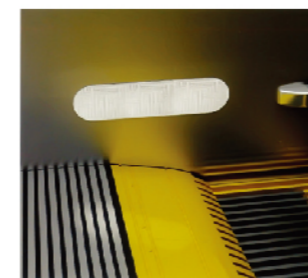

White LED

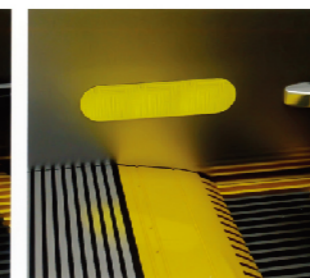

Yellow LED

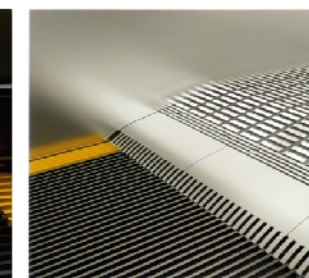

Aluminum

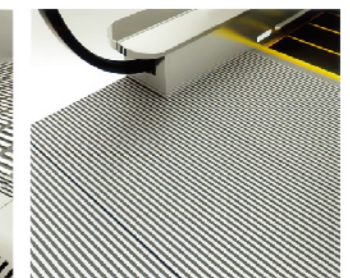

Aluminum

Comb teeth

Leading edge board, floor plate

43 / Small machine room elevator construction sketch

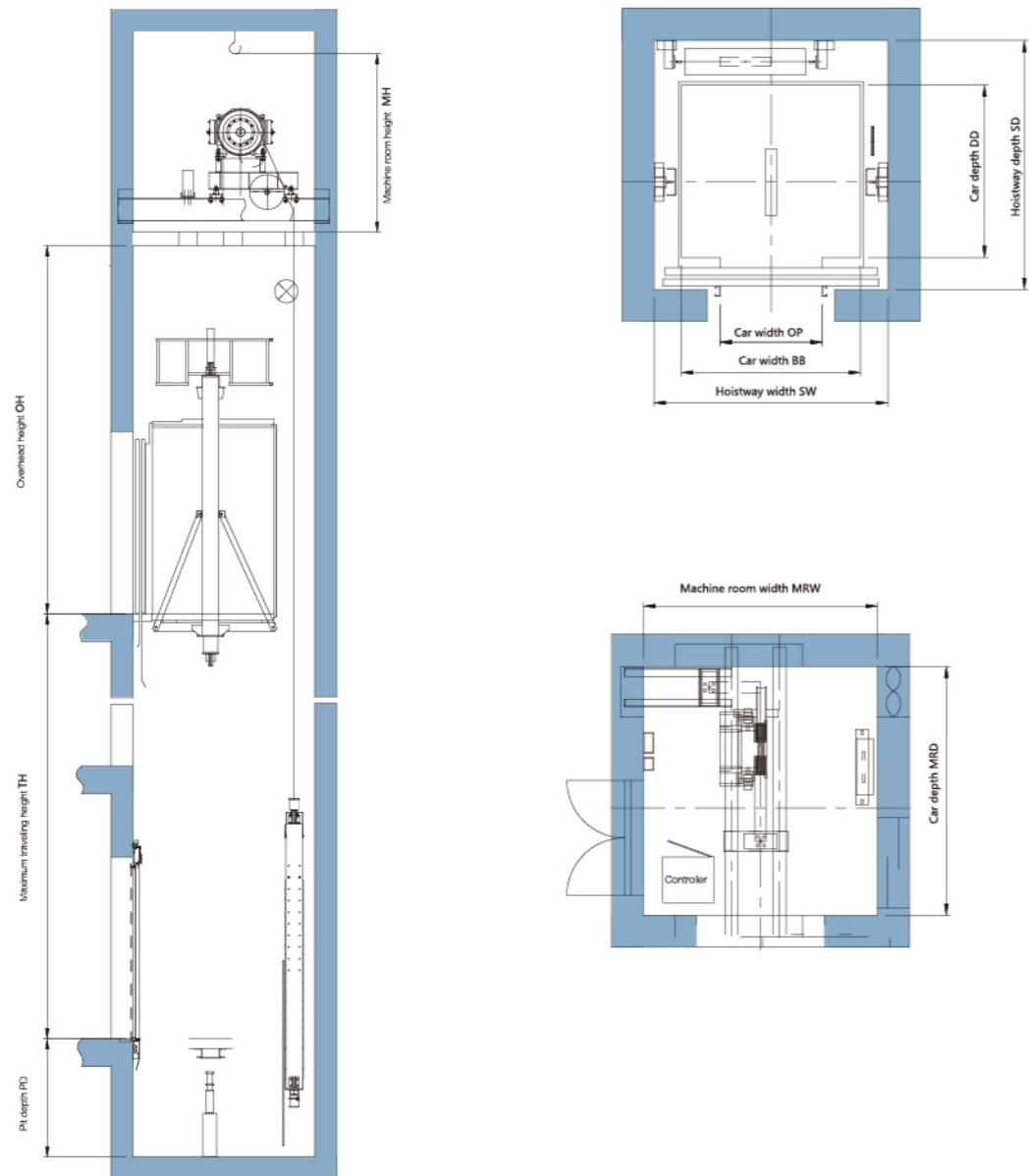

Q	V	BB	DD	OP	SW(mm)	SD(mm)	Min PH	Min OH	Max N	Max R	Min TH	Min D	power	
													P	DBGRB
(kg)	(m/s)	(mm)	(mm)	(mm)	Min	Min	(mm)	(mm)		(m)	(m)	(m)	(KW)	(mm)
630	1	1400	1100	800	1830	1700	1500	4350	20	60	5	2.7	4.6	2500
	1.5						1600	4500	24	75	6		6.9	
	1.75						1600	4550	30	90	7		8.1	
800	1	1400	1350	800	1830	1950	1500	4350	20	60	5	2.7	5.5	2500
	1.5						1600	4500	24	75	6		8.3	
	1.75						1600	4550	30	90	7		9.7	
1000	1	1600	1400	900	2050	2000	1500	4350	20	60	5	2.7	6.7	2000
	1.5						1600	4500	24	75	6		10	
	1.75						1600	4550	30	90	7		11.7	
1150	1.0	2000	1350	1100	2500	2100	1550	4350	20	60	5	2.7	8.7	2000
	1.5						1600	4500	24	75	6		12.8	
	1.75						1650	4550	30	90	7		14.8	
1350	1.0	2000	1500	1100	2500	2150	1550	4350	20	60	5	2.7	9.3	2000
	1.5						1600	4500	24	75	6		13.9	
	1.75						1650	4550	30	90	7		16.1	
1600	1.0	2000	1700	1100	2500	2350	1550	4350	20	60	5	2.7	11	2000
	1.5						1600	4500	24	75	6		16.4	
	1.75						1650	4550	30	90	7		19.2	

Machine roomless elevator construction sketch

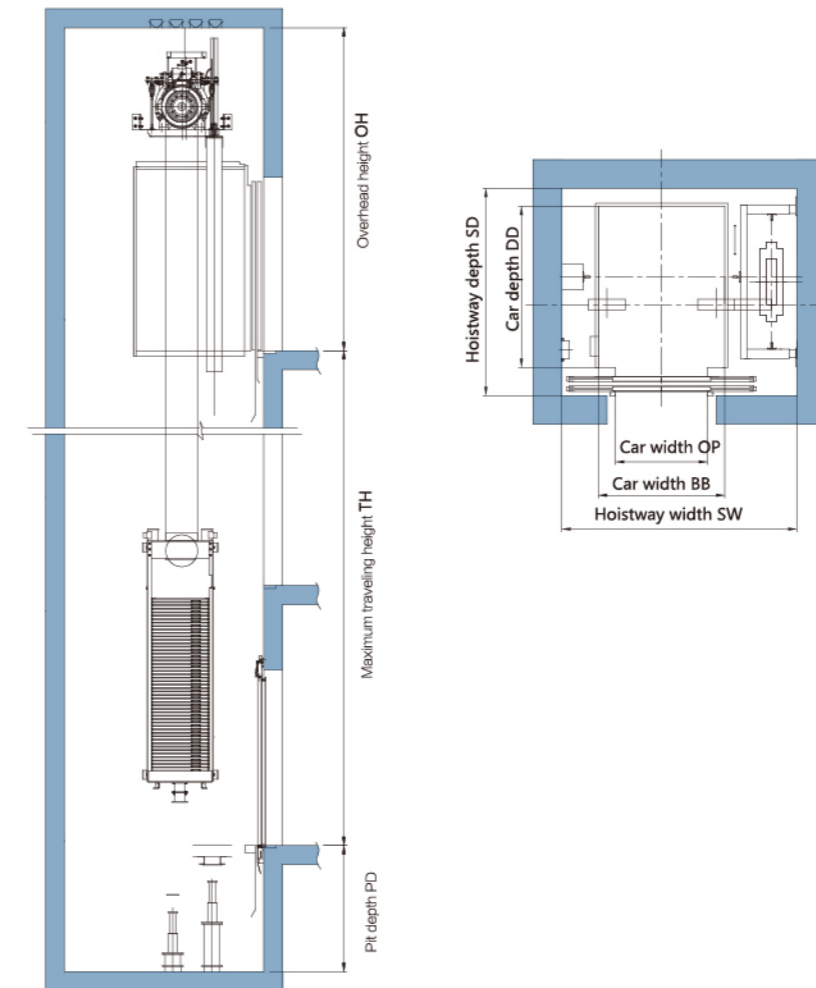

Q	V	BB	DD	OP	SW(mm)	SD(mm)	Min PH	Min OH	Max N	Min TH	Min D	power		
												P	DBGRB	
(kg)	(m/s)	(mm)	(mm)	(mm)	Min	Min	(mm)	(mm)		(m)	(m)	(KW)	(mm)	
630	1	1100	1400	800	2040	1800	1500	4200	20	55	2.7	4.3	2500	
	1.5						1600	4300	20	75		6.4		
	1.75						1700	4400	27	75		7.4		
800	1	1350	1400	800	2200	1800	1500	4200	20	55	2.7	5.4	2500	
	1.5						1600	4300	27	75		8.1		
	1.75						1700	4400	37	100		9.4		
1000	1	1500	1600	900	2350	2000	1700	4500	37	100	2.7	9.8	2000	
	1.5						1900	4700	44	120		12.3		
	2						1500	4200	20	55		6.6		
1150	1	1600	1650	1000	2550	2150	1600	4300	27	75	2.7	10.1	2000	
	1.5						1700	4400	37	100		11.6		
	1.75						1700	4500	37	100		12.3		
1250	1	1600	1800	1000	2550	2200	1900	4700	44	120	2.7	15.3	2000	
	1.5						1500	4250	20	55		7		
	2						1600	4300	27	75		10.6		
1350	1	1600	1900	1100	2700	2400	1700	4400	27	75	2.7	12.3	2000	
	1.5						1700	4500	37	100		14.1		
	1.75						1700	4500	37	100		14.3		
1600	1	1800	1900	1100	2800	2400	1900	4700	44	120	2.7	17.6	2000	
	1.5						1500	4250	20	55		8.2		
	2						1600	4300	27	75		12.3		
1600	1	2000	1700	1100	2500	2350	1500	4250	20	55	2.7	8.8	2000	
	1.5						1600	4300	27	75		13.2		
	1.75						1700	4400	37	100		15.4		
1600	1	2000	1700	1100	2500	2350	1550	4350	20	60	2.7	9.3	2000	
	1.5						1600	4500	24	75		6		13.9
	1.75						1650	4550	30	90		7		16.1
1600	1	2000	1700	1100	2500	2350	1550	4350	20	60	2.7	11	2000	
	1.5						1600	4500	24	75		6		16.4
	1.75						1650	4550	30	90		7		19.2

45 / Machine room panoramic construction sketch

Hoistway elevational drawing

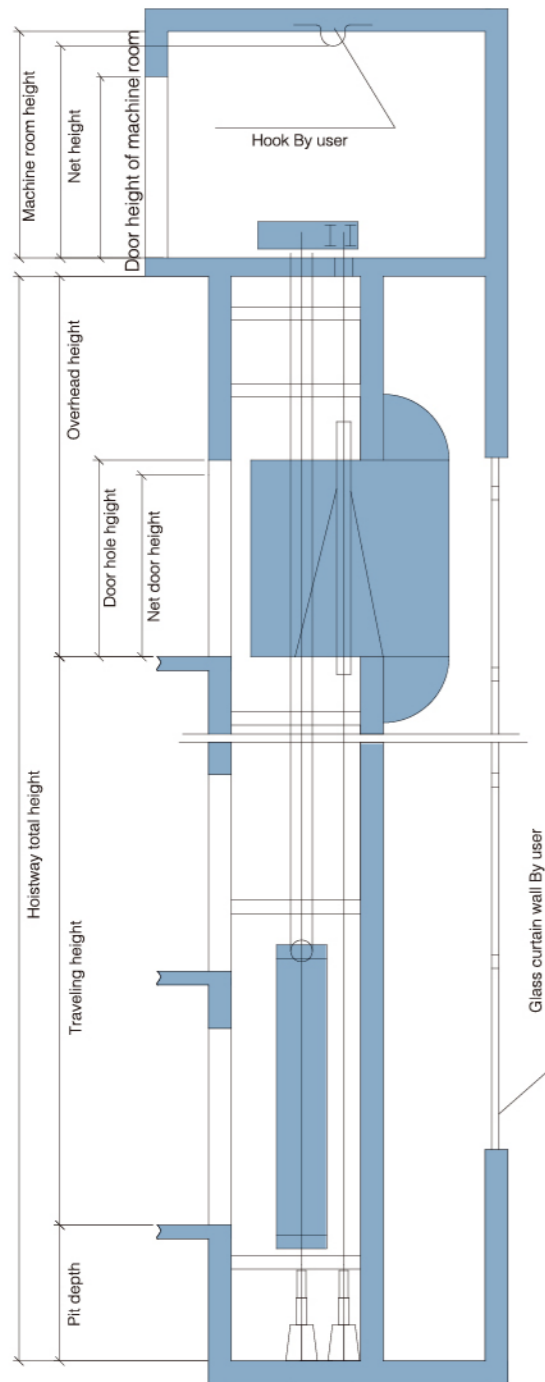

Machine room plan layout

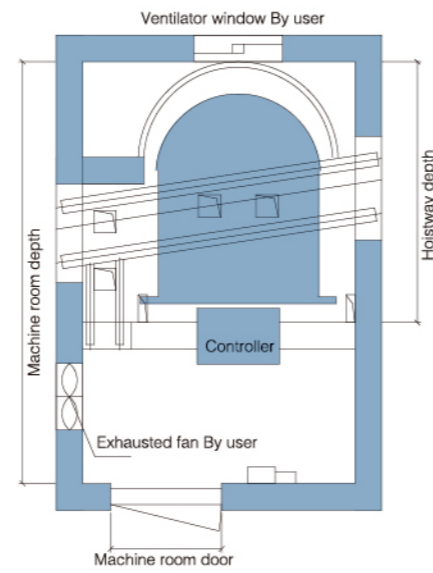

Hoistway elevational drawing

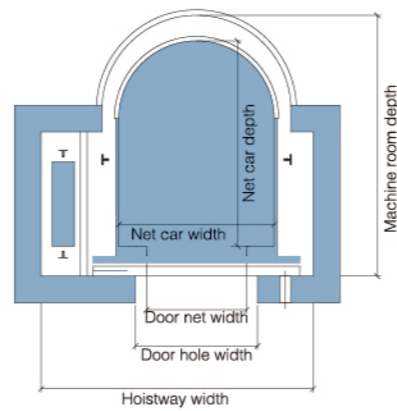

Machine room plan layout

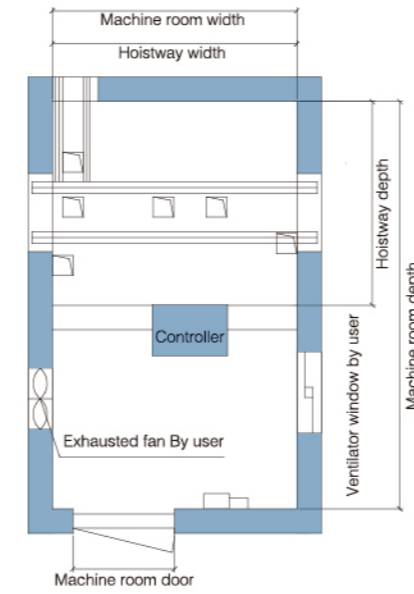

Hoistway elevational drawing

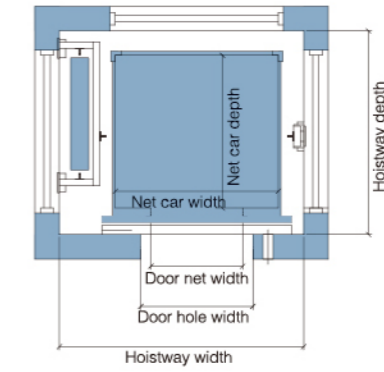

Machine room panoramic elevator construction parameters

Load(kg)	Speed (m/s)	Car dimension(mm)			Door-opening size(mm)	Hoistway size(mm)			Machine room size(mm)			Overhead height (OH)	Pit depth (PP)	
		Inner size AxB				Door net oppning	XxY			SxT				
		Square	Round	Diamond			Square	Round	Diamond	Square	Round			Diamond
630	1.0				800	2200x1700	2150x2250	2150x2250	2200x4000	2150x4000	2150x4000	4800	1700	
	1.5	1400x1100	1300x1700	1300x1700								4900	1800	
	1.75											5000	1900	
	2.0											5100	2000	
800	1.0				800	2200x1800	2350x2250	2350x2250	2200x4000	2350x4000	2350x4000	4800	1700	
	1.5	1400x1350	1300x1700	1300x1700								4900	1800	
	1.75											5000	1900	
	2.0											5100	2000	
1000	1.0				900	2400x2000	2450x2350	2450x2350	2400x4000	2450x4000	2450x4000	4800	1700	
	1.5	1600x1500	1400x1850	1400x1850								4900	1800	
	1.75											5000	1900	
	2.0											5100	2000	
1250	1.0				900/1100	2600x2100	2350x2650	2350x2650	2600x4000	2350x4000	2350x4000	4800	1700	
	1.5	1800x1550	1400x2150	1400x2150								4900	1800	
	1.75											5000	1900	
	2.0											5100	2000	
1600	1.0				1000/1100	2750x2200	2500x2850	2500x2850	2750x4000	2500x4000	2500x4000	4800	1700	
	1.5	1950x1700	1500x2300	1500x2300								4900	1800	
	1.75											5000	1900	
	2.0											5100	2000	

47 / Machine roomless panoramic construction sketch

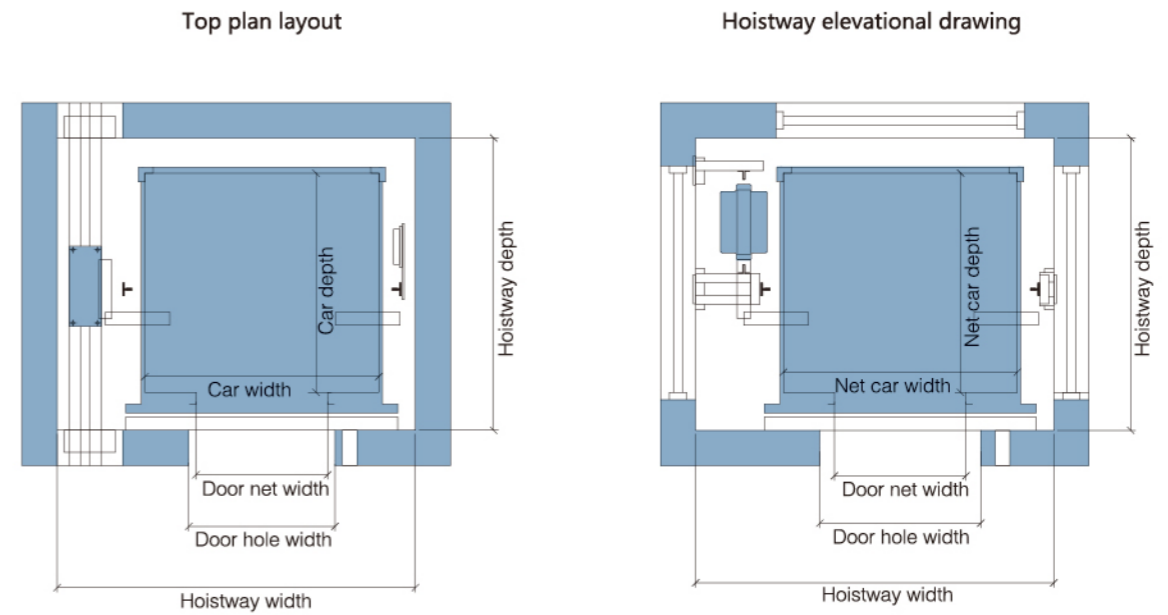
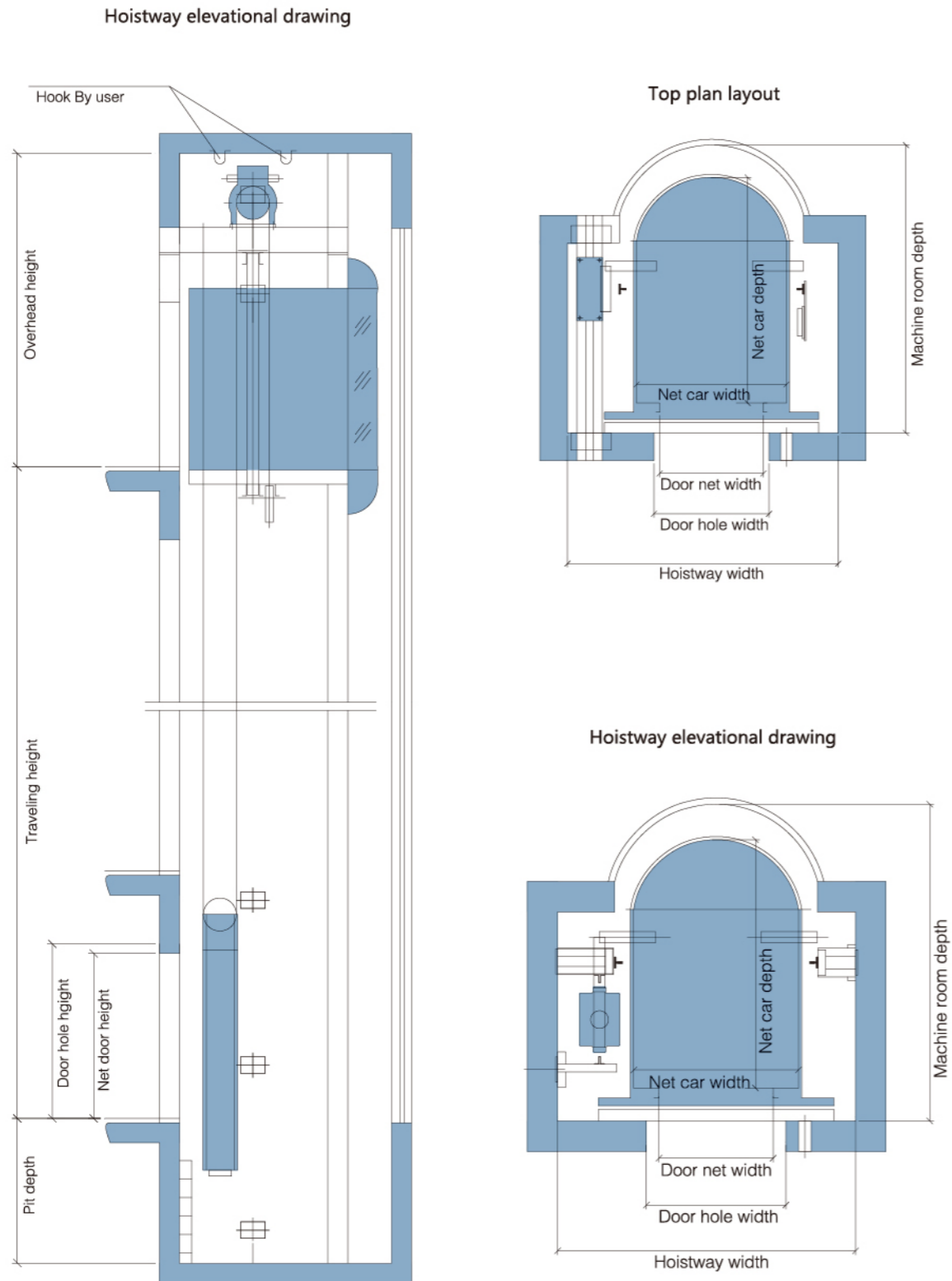

Machine roomless panoramic elevator construction parameters

Load(kg)	Speed (m/s)	Car dimension(mm)			Door-opening size(mm)	Hoistway size(mm)			Overhead height (OH)	Pit depth (PP)
		Inner size AxB			Door net oppning	XxY				
		Square	Round	Diamond		Square	Round	Diamond		
630	1.0	1400x1100	/	/	800	2250x1700	/	/	4800	1700
	1.5								4900	1800
	1.75								5000	1900
	2.0								5100	2000
800	1.0	1400x1350	1100x1960	1100x1960	800	2250x1800	2150x2500	2150x2500	4800	1700
	1.5								4900	1800
	1.75								5000	1900
	2.0								5100	2000
1000	1.0	1600x1500	1300x1960	1300x1960	900	2450x2000	2350x2500	2350x2500	4800	1700
	1.5								4900	1800
	1.75								5000	1900
	2.0								5100	2000
1250	1.0	1800x1550	1400x2150	1400x2150	900/1100	2650x2100	2500x2650	2500x2650	4800	1700
	1.5								4900	1800
	1.75								5000	1900
	2.0								5100	2000
1600	1.0	1950x1700	1500x2300	1500x2300	1000/1100	2800x2200	2600x2850	2600x2850	4800	1700
	1.5								4900	1800
	1.75								5000	1900
	2.0								5100	2000

49 Machine room freight elevator construction sketch

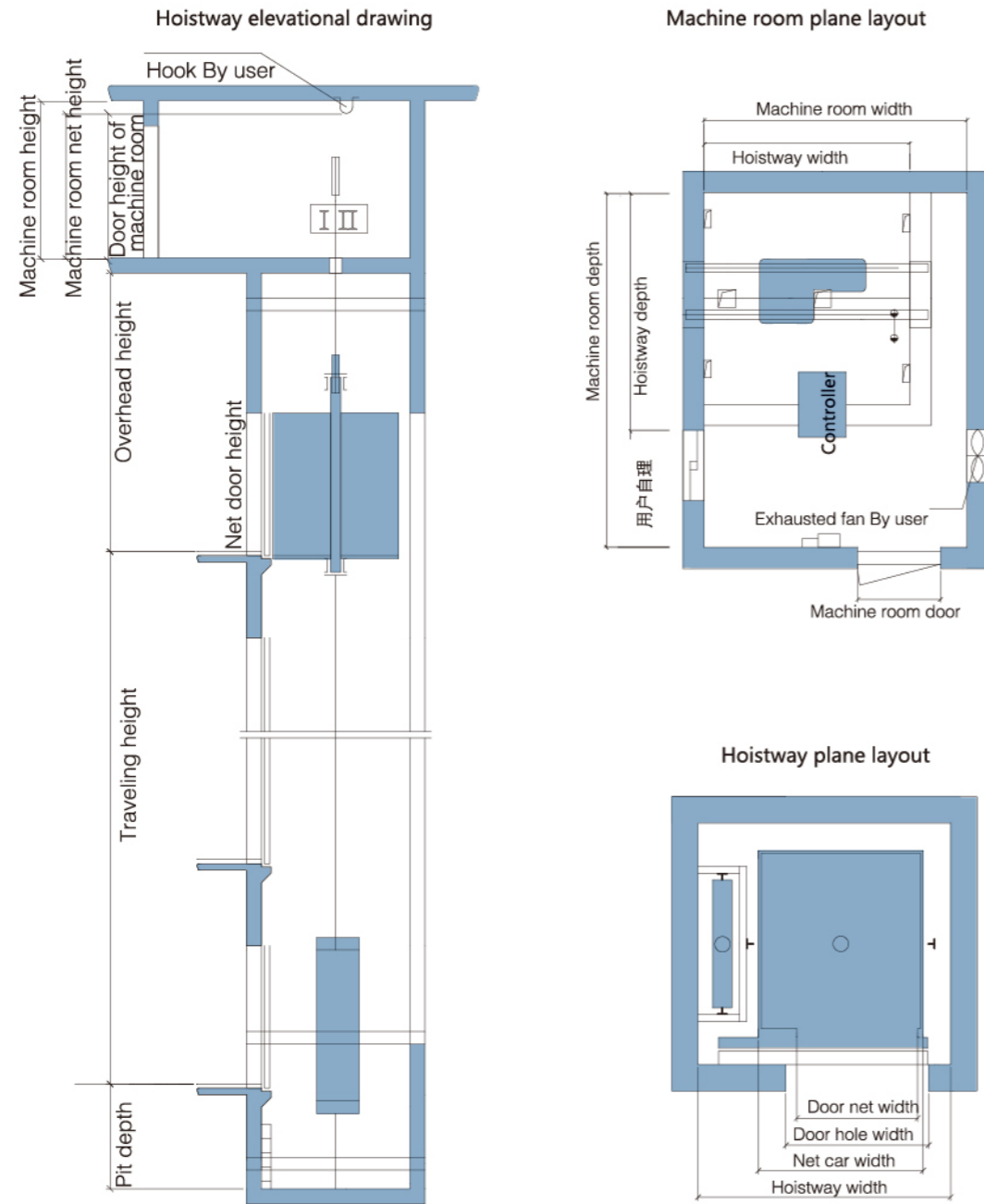

Freight elevator construction parameters

Load (kg)	Speed (m/s)	Car size	Door-open size		Hoistway size	Machine room size	Overhead height (OH)	Pit depth (PP)
			Door net opening	Net door height				
1000	0.5	1500x1800	1100	2200	2300x2200	3000x3000	4500	1500
2000	0.5	2000x2350	1500	2200	2850x2700	3500x4000	4500	1500
3000	0.5	2050x3050	2000	2200	3450x3400	4000x4500	4600	1500
5000	0.5	2450x3750	2400	2400	4000x4300	4500x5000	5000	1500

Machine roomless freight elevator construction sketch

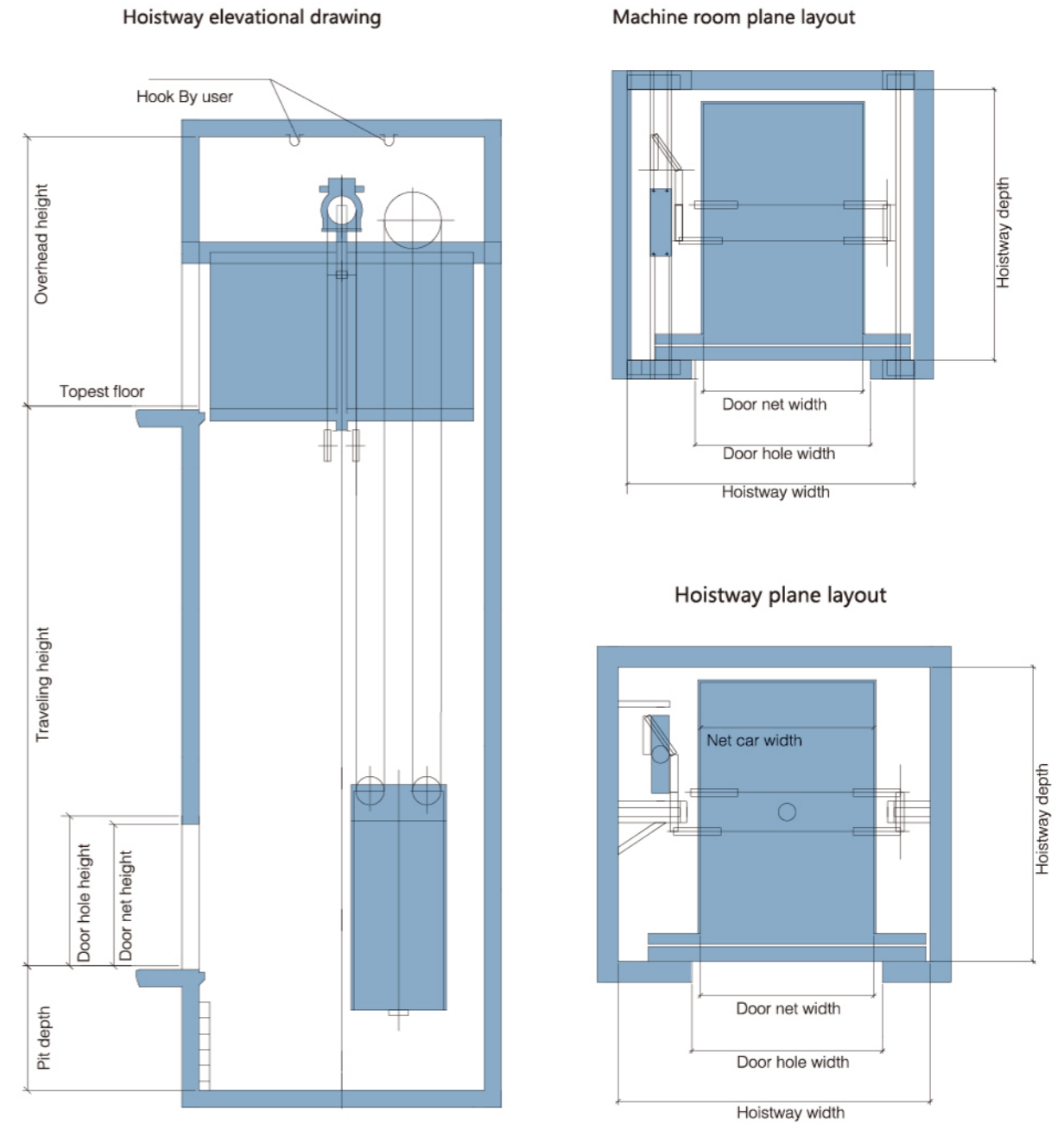

Machine roomless freight elevator construction parameters

Load (kg)	Speed (m/s)	Car size	Door-open size		Hoistway size	Overhead height (OH)	Pit depth (PP)
			Door net opening	Net door height			
1600	0.5	1650x2350	1400	2200	3000x3000	4700	1700
	1.0					4800	1800
2000	0.5	2000x2350	1500	2200	3350x3000	4800	1700
	1.0					4900	1800
3000	0.5	2050x3050	2000	2200	3600x3400	5000	1700
	1.0					5100	1800

51 / Automobile elevator construction sketch

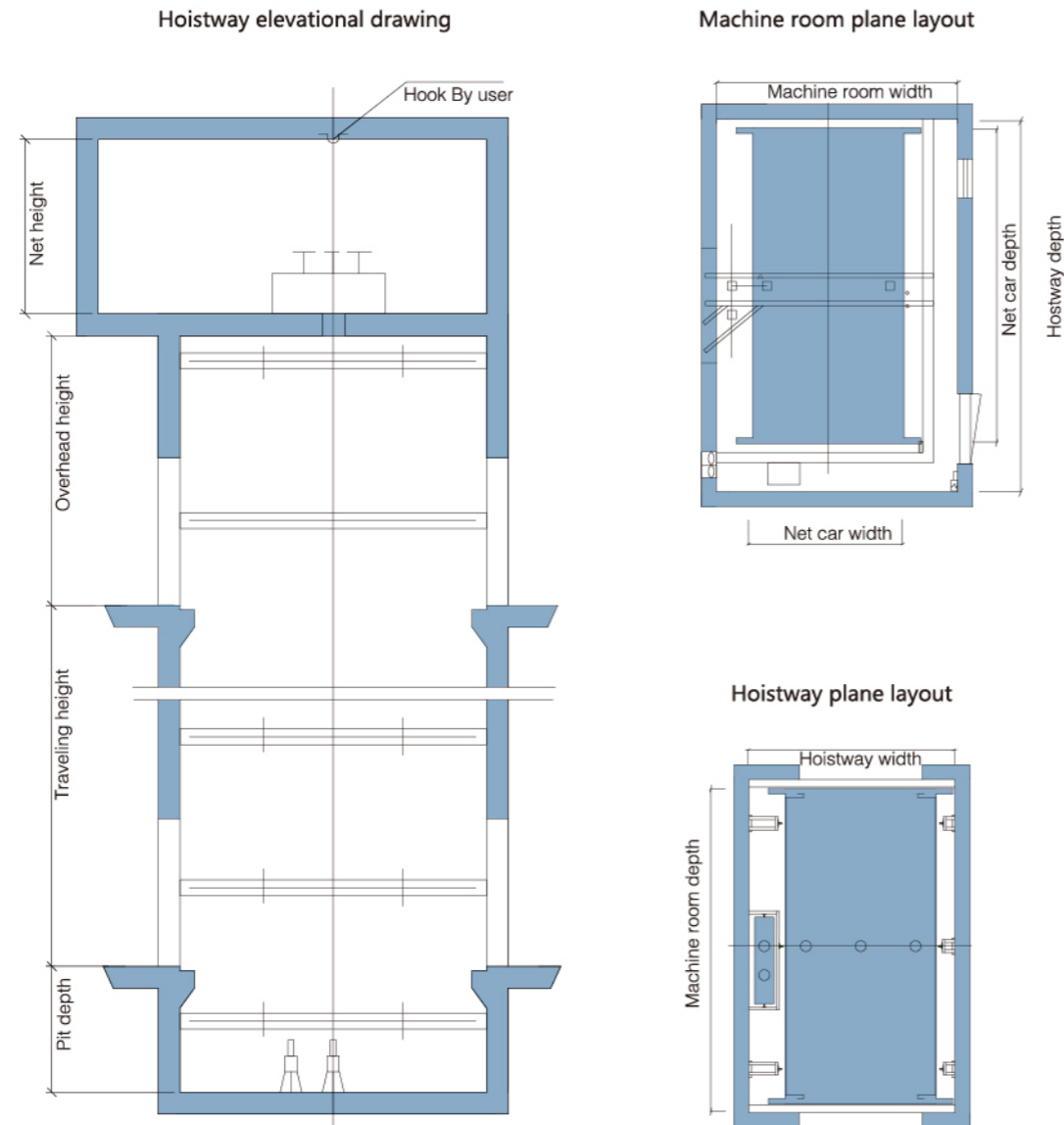

Automobile elevator construction parameters

Rated Carrying	Rated Speed	Model	Car		Floor Door		Hoistway				Generator room With one elevator		
			AA W	BB D	M	HH	AH	BH	PP	OH	AM	BM	HM
kg	m/s		mm	mm	mm	mm	mm	mm	mm	mm	mm	mm	mm
3000	0.5	ESN3000/0.5-XHW-VVVF	2700	5500	2500	2200	4200	6300	1600	4800	4500	7000	2800
5000	0.5	ESN5000/0.5-XHW-VVVF	3400	6800	2800	2400	4800	7600	1600	5200	5200	8500	2800

Dumbwaiter elevator construction sketch

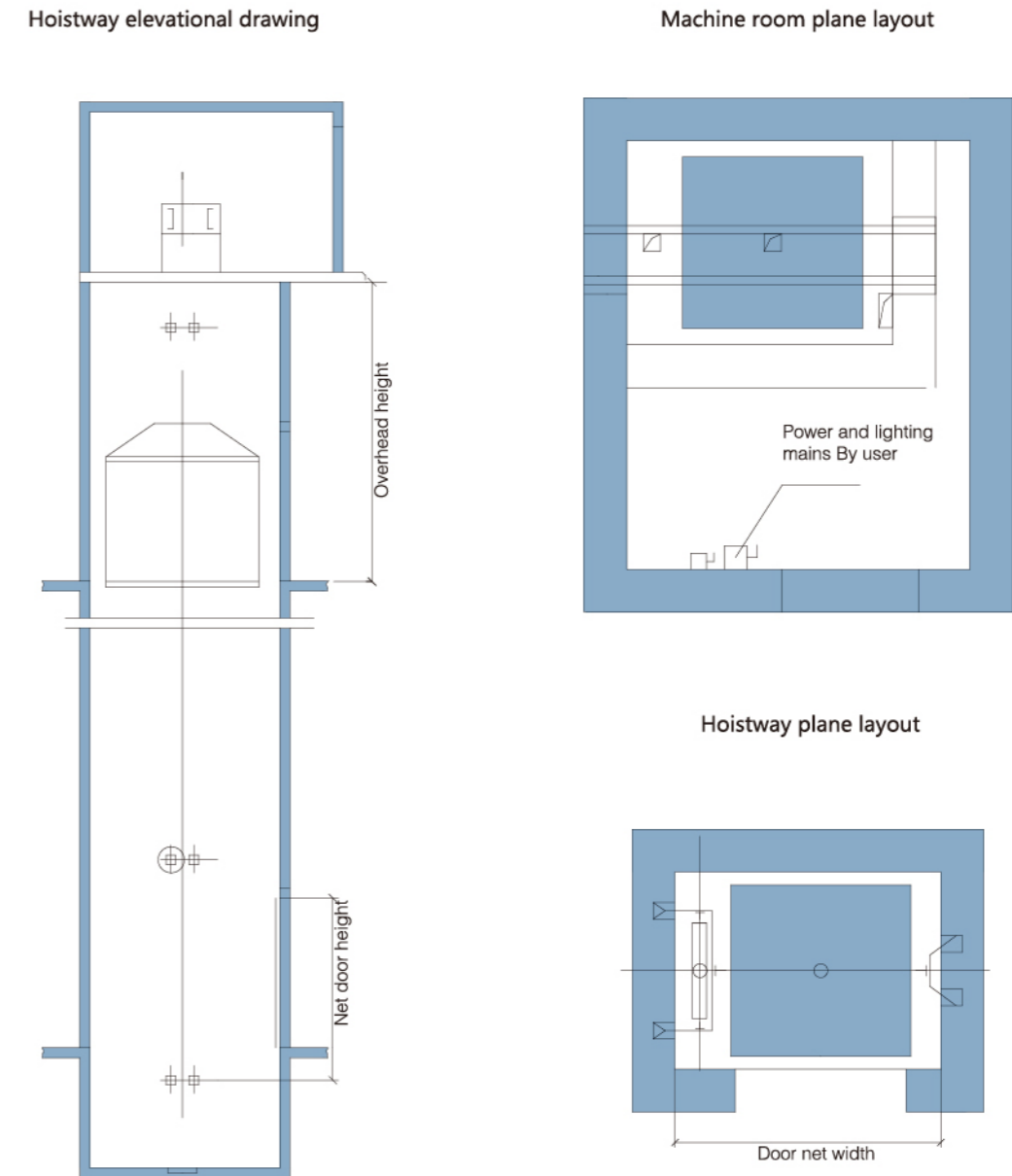

Dumbwaiter elevator construction parameters

Load (kg)	Speed (m/s)	Car size	Door-open size		Hoistwaysize XxY	Overhead height (OH)	Pit depth (PP)
			Door net oppning	Net door height			
100	0.25	800x800	800	900	1300x1000	2500	600
200	0.25	1000x1000	1000	1200	1600x1200	2500	1000
250	0.25	1100x1100	1100	1200	1700x1300	2500	1000

53 Home elevator construction sketch

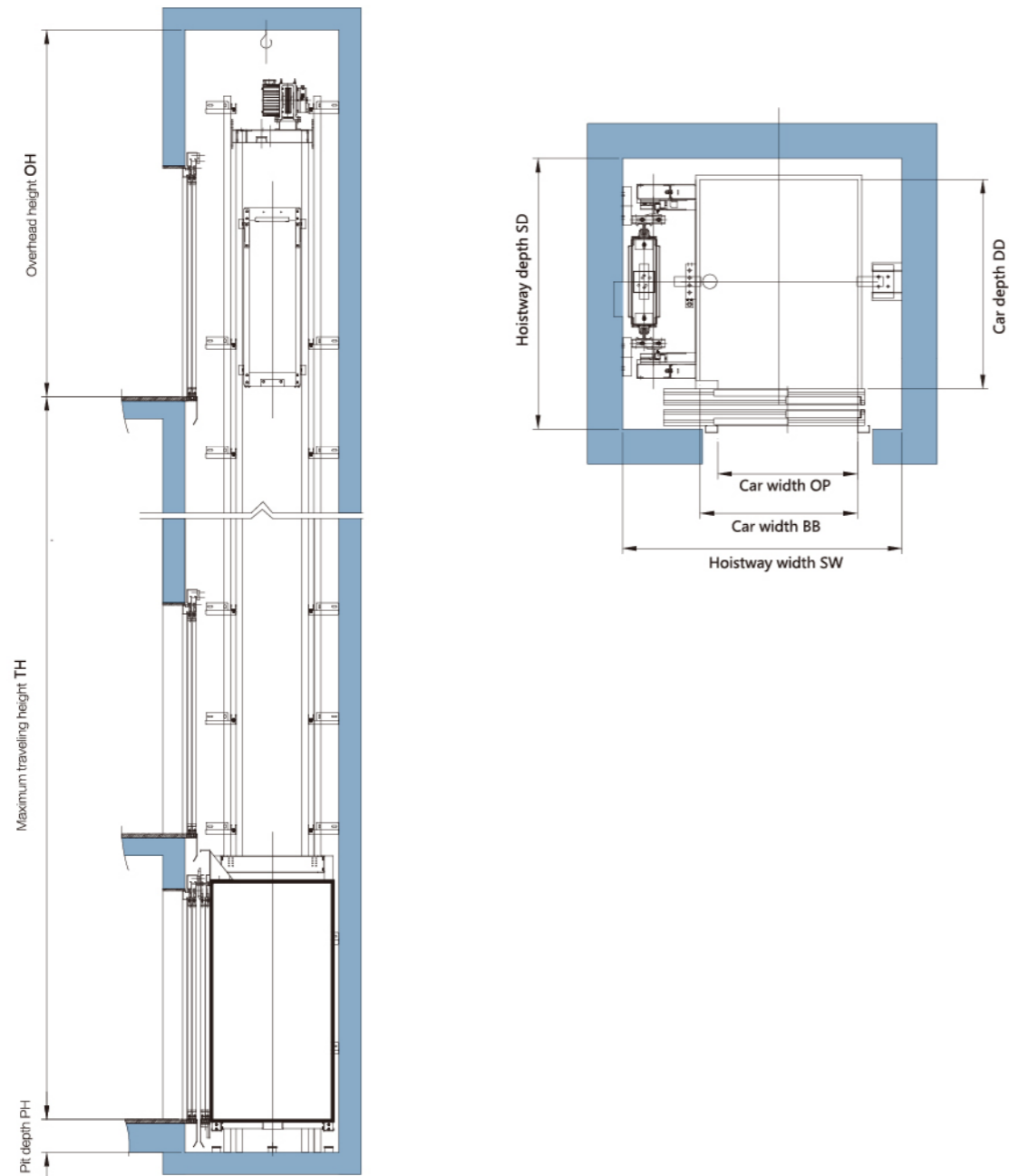

Normal household ladder

Q (kg)	V (m/s)	BB (mm)	DD (mm)	OP (mm)	SW(mm) Min	SD(mm) Min	Min PH (mm)	Min OH (mm)	Max N	Max TH (m)	Min D (m)	power	
												P (kw)	DBGRB (mm)
250	0.4	900	1200	700	1600	1600	500	3200	4	12	2.7	0.9	1500
320	0.4	1000	1200	800	1700								
400	0.4	1100			1800								

Household ladder backpack rack form

Q (kg)	V (m/s)	Backpack rack Arrangement mode	Car size					Min PH (mm)	Min OH (mm)	Max N	Max TH (m)	Min D (m)	power	
			BB (mm)	DD (mm)	OP (mm)	SW(mm) Min	SD(mm) Min						P (kw)	DBGRB (mm)
250	0.4	Side	800	1250	700	1400	1650	500	3100	4	12	2.7	0.9	1500
320	0.4	Side	900	1250	800	1500								
400	0.4	Side	1000	1300		1650								

Hospital elevator construction sketch

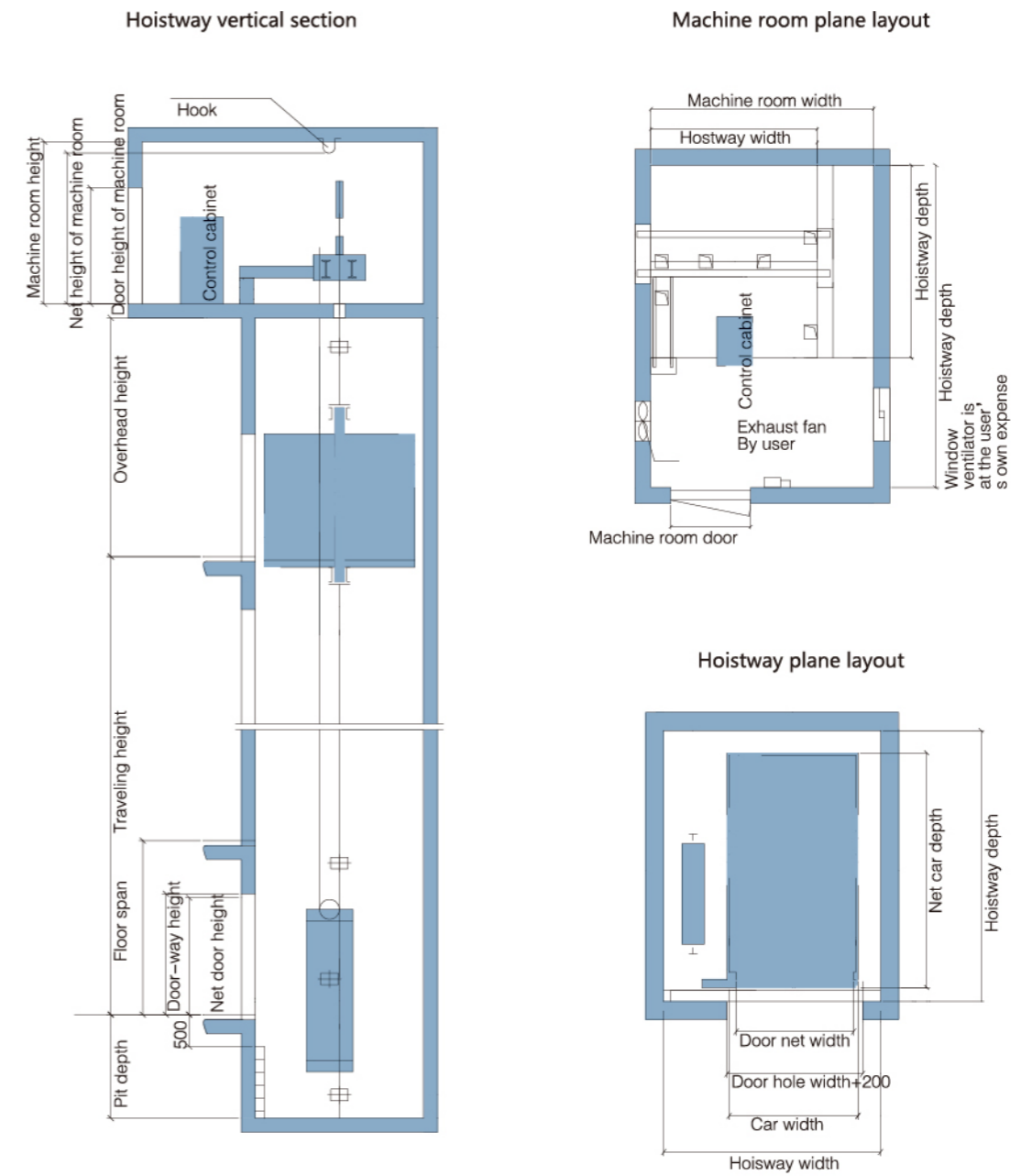

Hospital elevator construction parameters

(KG) Load	(MS) Speed	Car-size	Door-opening size(mm)	Hoistway size(mm)	Machine room size	(OH) Overhead height (OH)	(PP) Pit depth
		Outer size	Door net opening	X×Y	S×T		
1600	1.0	1400×2400	1200	2500×3000	2500×5000	4800	1500
	1.75					4900	1800
	2.0					5000	2000
2000	1.0	1600×2500	1300	2700×3100	2700×5000	4800	1500
	1.75					4900	1800
	2.0					5000	2000

57 / 0° moving walkway construction sketch

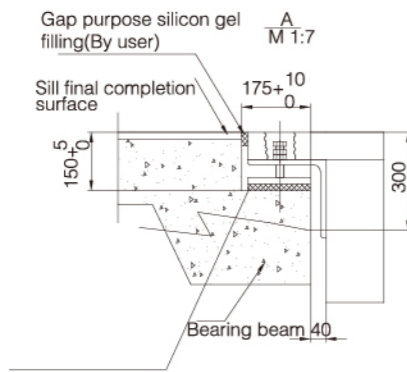
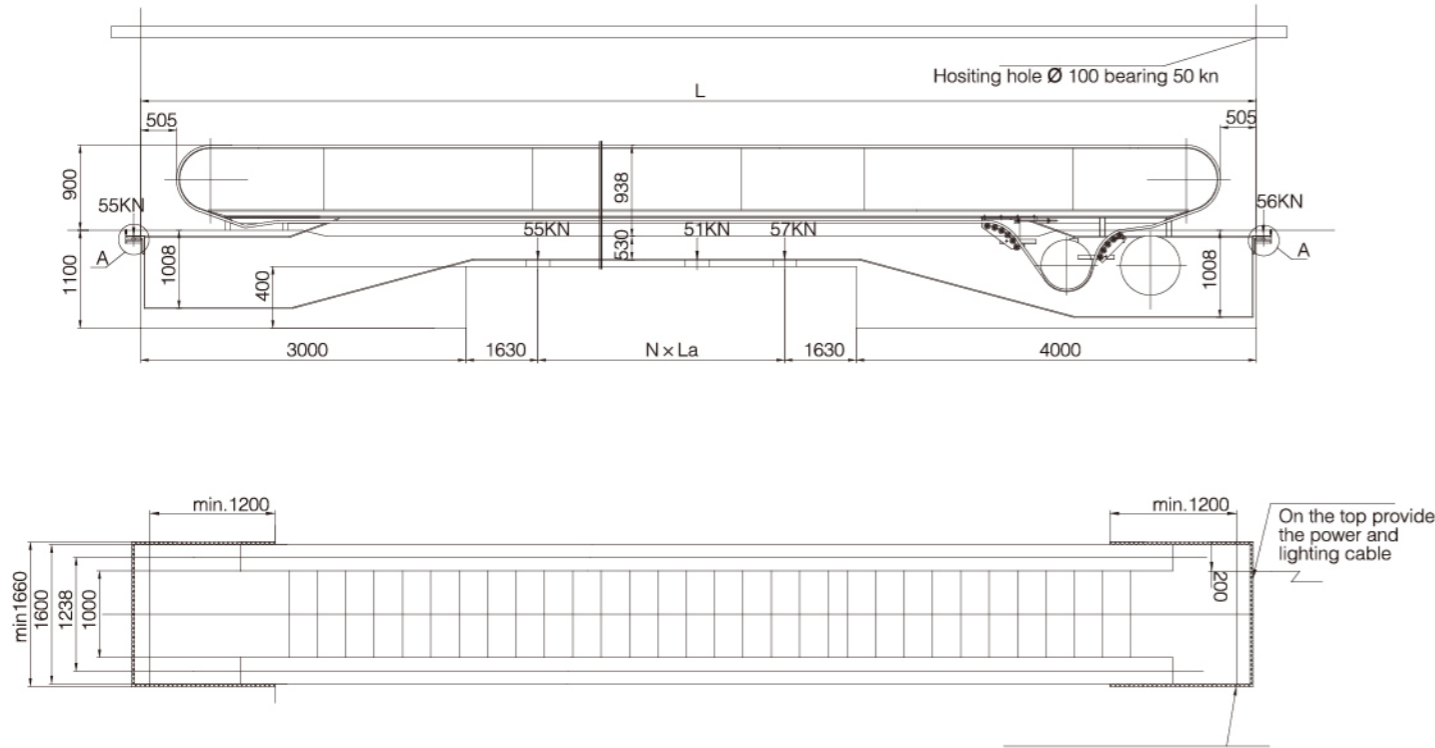

It should fill or cover the gap between the machine and the construction. The user should take care of the standard which is applicable for the well width.

Pre-embedded steel plate 160x20xE (By user)

Model	Traveling height	Rated speed	Rated load capacity	Inclination	Motor power	A(mm)	B(mm)	C(mm)	D(mm)
ESN (800/0°)	80000	0.5	6750	0	5.5	800	1038	1400	≥1460
	80000 < L ≤ 130000				8				
	130000 < L ≤ 150000				11				
ESN (1000/0°)	70000	0.5	9000	0	5.5	1000	1238	1600	≥1660
	70000 < L ≤ 110000				8				
	110000 < L ≤ 150000				11				

12° moving walkway construction sketch

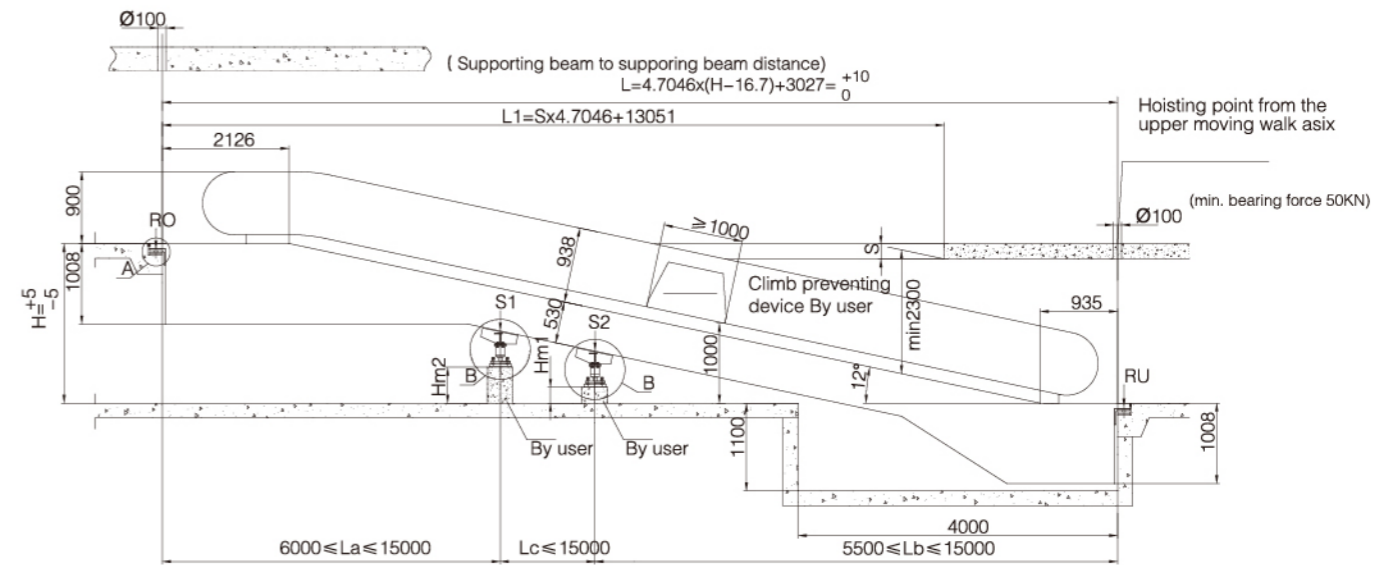

It supplies the dynamic force and lighting cable in the upper part

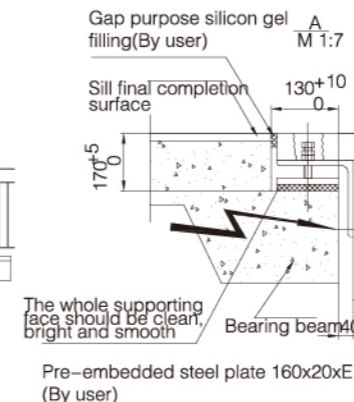
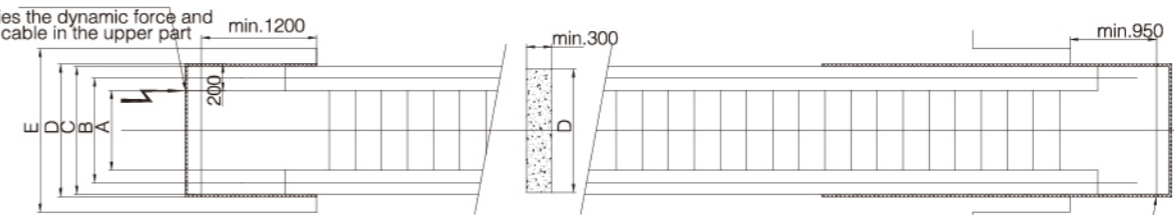

It should fill or cover the gap between the machine and the construction. The user should take care of the standard which is applicable for the well width.

The whole supporting face should be clear, bright and smooth

Pre-embedded steel plate 160x20xE (By user)

The construction supporting force includes the vibration load		
No intermediate supporting	One intermediate supporting	2 intermediate supporting
$R_o = 0.0045XL + 13$	$R_o = 0.0045XL_a + 13$	$R_o = 0.0045XL_a + 13$
$R_u = 0.0045XL + 7$	$R_u = 0.0045XL_b + 7$	$R_u = 0.0045XL_b + 7$
	$S_1 = 0.00585X(L_a + L_b)$	$S_1 = 0.00585X(L_a + L_c)$
		$S_2 = 0.00585X(L_b + L_c)$

Traveling height		In intermediate supporting		La (mm)	Lb (mm)	Lc (mm)
From	To	S1	S2			
1601	2663	-	-	-	-	-
2664	4151	1	-	L-7000	7000	-
4152	5851	1	-	15000	L-15000	-
5852	6000	1	1	15000	7000	L-22000

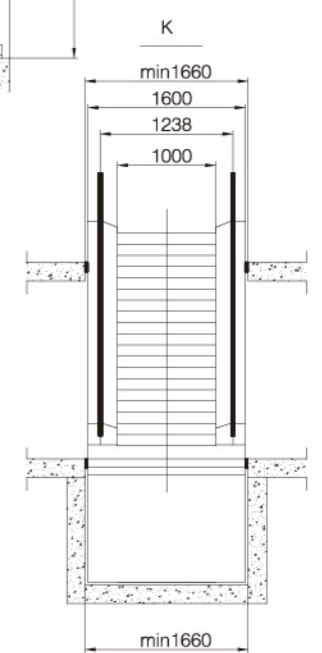

Classical projects

Through the years' market accumulation, ESNOW has become a comprehensive and excellent construction and traffic service provider. It is also first-choice for vast construction projects because of reliable quality, professional after sale service, rich product items.

ESNOW Elevator has successfully supplied vast vertical traffic solution plans for world-wide commercial buildings, residential projects, cultural landmarks, government buildings. It wins general approval and deep trust from broad customers.



Jamahkiri Resort-Thailand

Terrazze Building-Cambodia

Ichikawa Grand-India



Majed Al Deehany Kuwait-Africa

Chill Pepper Boutique-Dubai

Kavinga Guest House-America



Gable End-China

Grand Sihanouk Building-Japan

Thailand Baan Sansuk-Thailand

The Bloc Hotel-China



America Sacramento The Rivermark Corporate District

Balmoral House-Hongkong

Best Western Kenwick-India

One Central-Japan



Palacio Pinello-India

La Roca Edifice-India

Blue Jay Edifice-Dubai

Perry's Bridge Hollow Boutique Hotel-Africa

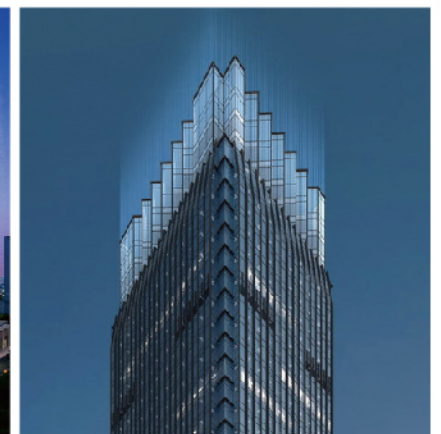

The Key Sathorn- Ratchapreuk

The Zentral Arenal Suites-America

Circa 51 Boutique Residence-Cambodia



Shimaya Building-Japan

Lotte Building-Korea

Suites Sevilla Plaza-Spain

Rissington Inn-Spain

Vincci La Rabida-Spain



Petit Palace Marques Santa Ana-India

The Tamarind-Spain

Apartamentos Óscar Valle-Spain

Metropolitan Takasaki-Japan